



Historical Biology

An International Journal of Paleobiology

ISSN: 0891-2963 (Print) 1029-2381 (Online) Journal homepage: <http://www.tandfonline.com/loi/ghbi20>

New models for the wing extension in pterosaurs

Edina Prondvai & David W.E. Hone

To cite this article: Edina Prondvai & David W.E. Hone (2008) New models for the wing extension in pterosaurs, *Historical Biology*, 20:4, 237-254, DOI: [10.1080/08912960902859334](https://doi.org/10.1080/08912960902859334)

To link to this article: <http://dx.doi.org/10.1080/08912960902859334>



Published online: 30 Jun 2009.



Submit your article to this journal [↗](#)



Article views: 89



View related articles [↗](#)



Citing articles: 7 View citing articles [↗](#)

New models for the wing extension in pterosaurs

Edina Prondvai^{a,*} and David W.E. Hone^{b,1}

^aDepartment of Palaeontology, Eötvös Loránd University, Pázmány Péter sétány 1/c, Budapest, 1117, Hungary; ^bInstitute of Vertebrate Palaeontology and Palaeoanthropology, Chinese Academy of Sciences, Beijing 100044, People's Republic of China

(Received 22 December 2008; final version received 17 February 2009)

All powered flying animals have to face the same energetic problems: operating the wings during steady flight with muscles that require constant energy input and neural control to work. Accordingly the extant flying vertebrates have apparently found very similar solutions to parts of these issues – the biomechanical automatism built in their skeletal, muscular and connective tissue system. Based on these extant analogues (birds and bats) two new models are presented here for the mechanism of the distal wing extension in pterosaurs, an extinct group of flying vertebrates. The elongate fourth finger which solely supported their extensive flight membrane was a long lever arm that experienced significant loads and for which a reduction in muscle mass through automatism would have been strongly beneficial. In the first model we hypothesize the presence of a propatagial ligament or ligamentous system which, as a result of the elbow extension, automatically performs and maintains the extension of the wing finger during flight and prohibits the hyperextension of the elbow. The second model has a co-operating bird-like propatagial ligamentous system and bat-like tendinous extensor muscle system on the forearm of the hypothetical pterosaur. Both models provide strong benefits to an animal with powered flight: (1) reduction of muscles and weight in the distal wing; (2) prevention of hyper extension of the elbow against drag; (3) automating wing extension and thereby reducing metabolic costs required to operate the pterosaurian locomotor apparatus. These models, although hypothetical, fit with the existing fossil evidence and lay down a basis for further biomechanical and/or aerodynamical investigations.

Keywords: pterosaur; wing extension; automatism; biomechanics

Introduction

Pterosaurs were the first actively flying vertebrates to evolve, lived in the Mesozoic Era and were a diverse and highly successful group. The key pterosaurian feature is the hypertrophied fourth manual digit that supports the main wing membrane (the brachiopatagium) which forms the primary flight surface (Figure 1). While they reached a great diversity in shape and size and adopted many ecological niches, other features such as the shape of the wing (Elgin et al. in prep) or the delicate body construction with hollow, thin walled bones and possible extensive pneumaticity (Witton 2008) were far more conservative. Additional flight membrane areas are the propatagium (fore membrane) and the uropatagium (hind membrane; Figure 1) about the structural details of which the fossil record yields only little information. Two main morphological groups of pterosaurs are generally distinguished: (1) the paraphyletic group of basal forms (earlier referred to as 'rhamphorhynchoids') with short neck, short metacarpal IV, long tail (except for anurognathids) and long, medially directed fifth toe; (2) pterodactyloids, the more derived, monophyletic clade with generally longer

neck, long metacarpal IV, short tail and reduced or lost fifth toe.

In the past, numerous papers have been published on the biomechanics of pterosaur flight (e.g. see Hankin and Watson 1914; Heptonstall 1971; Bramwell and Whitfield 1974; Hazlehurst and Rayner 1992; Frey et al. 2003, 2006; Chatterjee and Templin 2004; Wilkinson et al. 2006; Bennett 2007a, 2008), yet few have paid special attention to the obvious problem faced by pterosaurs: the flexion–extension of the enormously elongate wing finger (but see Frey et al. 2006; Bennett 2008) and its control during flight. This is an important problem that requires further study since the main distal pivot of the wing is the hinge-joint between the wing metacarpal and the wing finger, the latter of which is by far the longest lever arm along the leading edge of the wing among the actively flying vertebrates (Figure 1). The extremely enlarged wing finger raises the issue of how could such an enormous device have been manipulated by as little amount of muscles as possible to avoid significant mass increase especially in the distal wing and to minimize the energy output and the demand of higher neural control;

*Corresponding author. Email: prondvaie@gmail.com

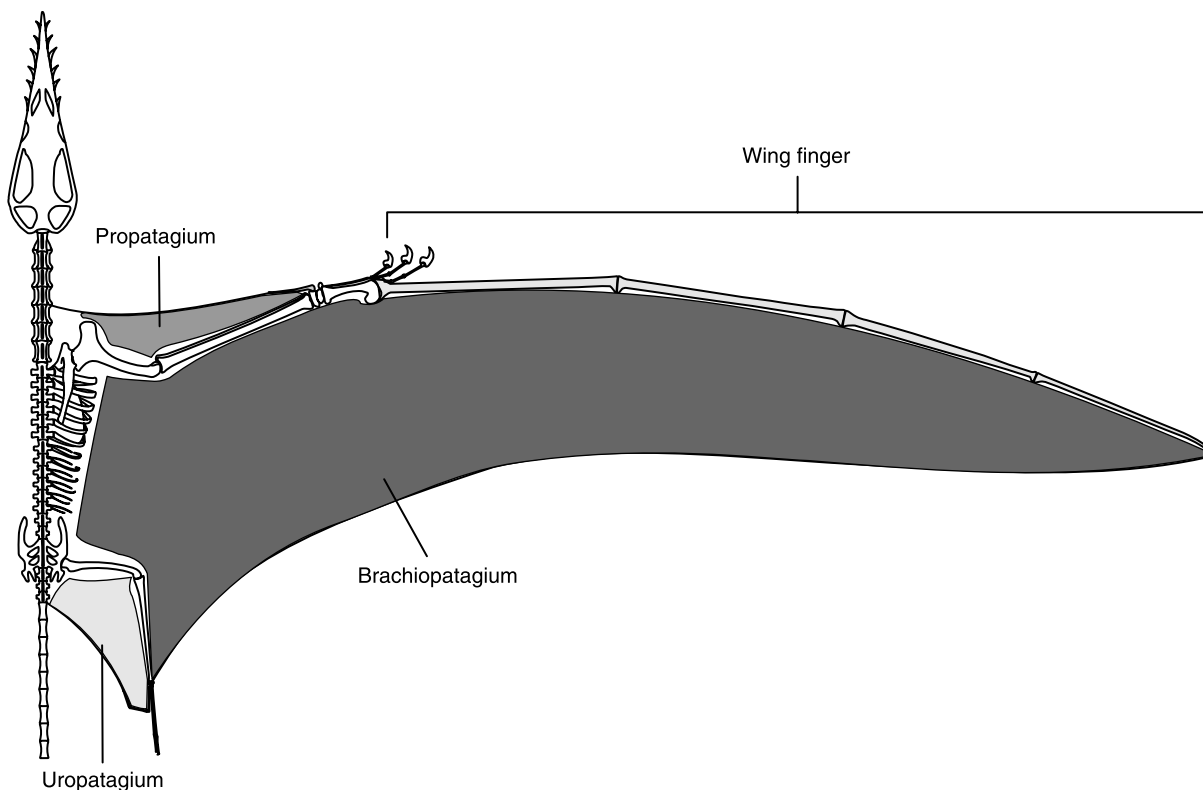

Figure 1. The long tailed Jurassic pterosaur *Rhamphorhynchus* showing some general features of pterosaurs. Note the elongated fourth manual digit, the so called wing finger and the different parts of the flight membrane: the propatagium (fore membrane), the brachioptagium (main wing membrane) and the uropatagium (hind membrane).

conditions which are prerequisites of sustainable flight. Therefore to elucidate the operating principle of flexion–extension is of interest concerning the stabilizing of this hinge-joint during gliding but becomes especially important in the context of flapping flight. Without understanding how pterosaurs could have controlled the movements in different parts of their wings during the flight stroke it is difficult to calculate the proper aerodynamics of pterosaur flapping flight or to place limitations on possible flight strokes.

The aim of the present study is to discuss the necessity of biomechanical automatism for flying animals and in view of this to provide a new hypothetical approach how pterosaurs could have operated and maintained the extension of the wing finger during steady flight. The models, while based on only very limited fossil evidence, are hypothetical and therefore intended only as a basis for future research, but still provide a framework for actual mechanical studies.

Institutional abbreviations:

AMHN: American Museum of Natural History, New York, USA

BSP: Bayerische Staatssammlung für Paläontologie und Geologie, München, Germany

Automatism and its significance in the wing function of extant flying vertebrates

The significance of biomechanical automatism in the moving parts of biological systems as a solution for energy saving is beyond doubt. The relative importance of energy saving mechanisms increases with the increasing energy requirement of different locomotion types. Considering the high demand of energy input of powered flight, the biomechanical automatism in the wing function is likely to be more favoured by the evolution and thereby to become necessary and essential for actively flying animals. The only powered fliers among extant vertebrates, birds and bats also confirm this notion by their use of such automation.

Operation in birds

The ability of birds to couple the movements of the elbow and wrist via bone-based automatism has first been described as the ‘drawing-parallels’ system by Bergman (1839). When the elbow flexes, the radius is forced to shift along the ulna toward the wrist and flex the manus and with it the whole distal wing (fused manual digits and primary feathers). This coordination is automatic and is mechanically built into the forelimb, since these coupled movements can be initiated on a dead bird (see Figure 2).

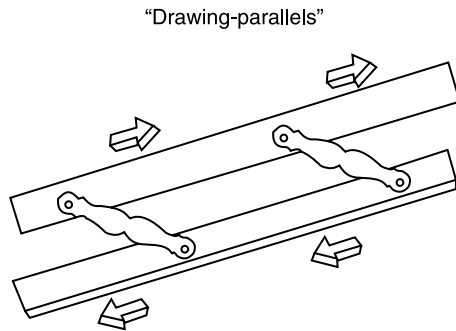

Figure 2. Drawing-parallels representing the analogous movement of the radius and ulna in the avian forelimb. (Figure modified from Vazquez 1994).

Vazquez (1994), however, pointed out that the original idea of Bergmann (1839) about ‘drawing-parallels’ in the wings of birds is more complicated in terms of the contribution of significant amount of passively acting muscles, tendons and ligaments to the flexion–extension process (‘drawing-parallels’ action of the forearm and the two-joint muscles of the wing are integrated).

In addition to this automatism via bone-linkage there is a merely soft-tissue-based automatic system which helps to operate the wings of birds even smoother and safer. This automatic mechanism is performed by two important ligaments which run in the propatagium: *Ligamentum propatagiale* (LP; frequently called as *m. tensor propatagialis*, McKittrick 1985; Solomon 1993; Corvidae et al. 2006) in the leading edge and *Ligamentum limitans cubiti* (LLC) in the most inner part, closer to the humeral shaft (Figure 3). According to Brown et al. (1994) the LP originates from one or the combination of

(1) the deltopectoral crest of the humerus; (2) the tendon of insertion of *m. pectoralis* or *m. deltoideus major* and (3) a tendinous band that merges with the muscle fascia of *m. pectoralis*; and inserts onto the joint capsules covering the distal radius, radiale and carpometacarpus and has a terminal extension on the alular digit. Concerning the histological structure Brown et al. (1994) distinguished three segments of LP: (1) proximal collagenous pars fibrosa (LP PPF); (2) medial pars elastica mainly composed of elastin (LP PE); (3) distal collagenous pars fibrosa (LP DPF). This complex histological structure ensures the proper functioning of LP in compliance with the given biomechanical constraints and enables active muscular control over the passively functioning LP. LLC was described by the same authors as originating from a common aponeurosis with the proximal attachment of LP, and with a separate band directly from the deltopectoral crest of the humerus and inserting proximally onto the tendon of origin of *m. extensor carpi radialis*, distal to the insertions of *m. biceps brachii* upon the antebrachium. (See Figure 3). These two structures function as follows: when the elbow extends, the distance between the origin and insertion of these ligaments (hence the tension in them) increases, thus LLC pulls on the antebrachium preventing hyperextension of the elbow, whereas the high tension of LP affects the wing extension distal to the carpus and acts to support it against the forces of drag that are constantly working to push the wing caudally (Brown et al. 1995). These ligaments function independently of any muscular support (Brown et al. 1994). The elastic nature of LP pars elastica maintains the possibility for minor corrections by independent muscle power (Figure 3(B)). However, the morphological and histological features of these structures cannot be generalized since

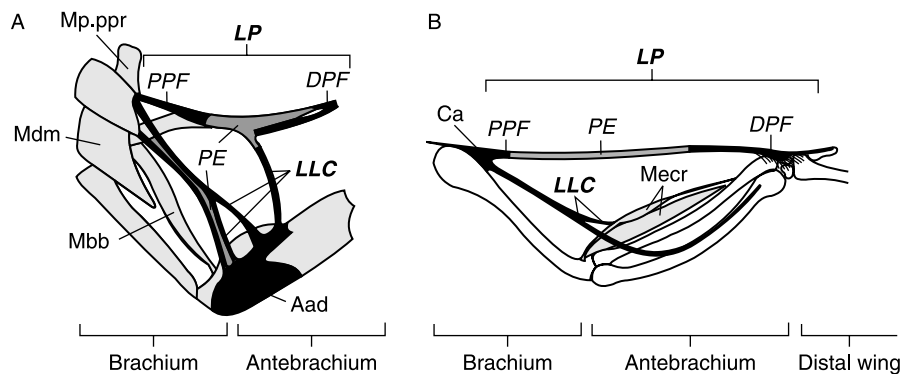

Figure 3. Propatagial ligaments and muscles in the wing of (A), ibis (*Eudocimus albus*) and (B), red-tailed hawk (*Buteo jamaicensis*) in dorsal view. Note the interspecific differences in the histological structure and the arrangement of the branches of LLC. Abbreviations: Aad: Aponeurosis antebrachialis dorsalis; Ca: common aponeurosis with which the *Ligamentum limitans cubiti* (LLC) and the *Lig. propatagiale* (LP) originate on the deltopectoral crest of the humerus; LLC: *Ligamentum limitans cubiti*; LP: *Ligamentum propatagiale*; Mbb: *Musculus biceps brachii*; Mdm: *Musculus deltoideus major*; Mecr: *Musculus extensor carpi radialis*; PE: pars elastica of LP and LLC; PPF and DPF: proximal and distal pars fibrosa of LP, respectively; Mp.ppr: *Musculus pectoralis pars propatagialis*; (Figures modified from (A), NAA-2, Baumel 1993; (B), Brown et al. 1995).

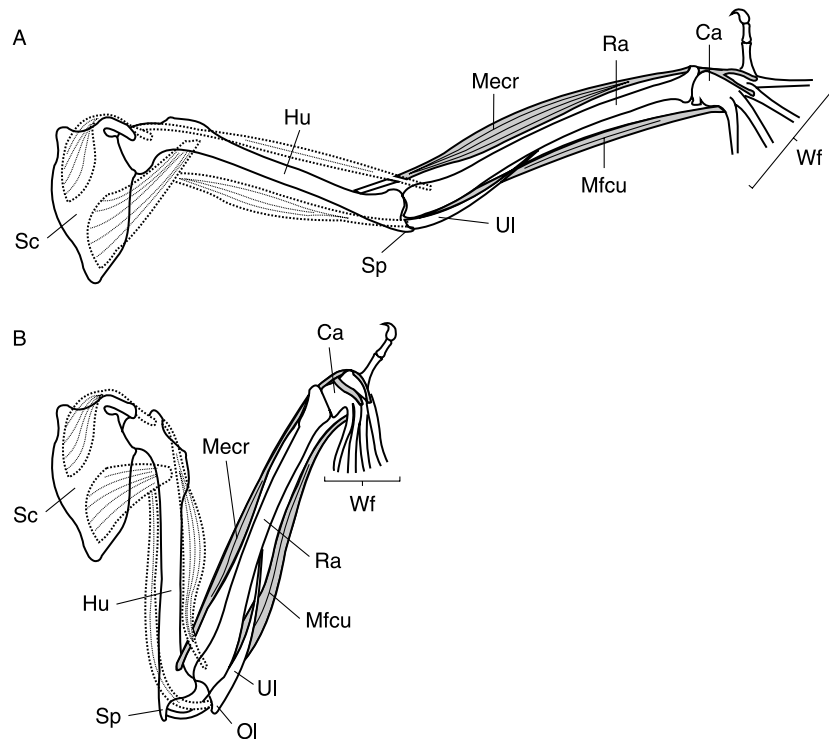

Figure 4. General line drawing of the automatic tendino-muscular extensor-flexor system in the antebrachium of bats. The inelastic and tendinous extensor muscles, *m. extensor carpi radialis longus et brevis* (Mecr) automatically pull on the distal wing with very limited overall muscle power when the elbow is extended. The antagonist *m. flexor carpi ulnaris* (Mfcu) has a similar construction and automatically pulls on the fifth metacarpal when the elbow is actively flexed and thereby partially collapses the dactylopatagium. Abbreviations: Ca: carpus; Hu: humerus; Mecr: *musculus extensor carpi radialis*; Mfcu: *musculus flexor carpi ulnaris*; Ol: olecranon process of the ulna; Ra: radius; Sc: scapula; Sp: spinous process of the humerus; Wf: wing fingers. (Figure modified from Hill and Smith 1984).

there are significant differences among different taxa (e.g. branches of *LLC*; the presence or absence of the elastic part of *LP* etc.; Baumel 1993; see Figure 3). The function of the propatagial ligaments in birds can be summarized as follows: (1) these ligaments in birds prevent the deformation of the propatagial contour and the hyperextension of the elbow against the drag, (2) in co-operation with the skeletoligamentous linkage it forms an integrated wing extension–flexion control mechanism (Brown et al. 1995) and (3) along with other propatagial tendons not described here it acts to extend the manus in unison with the forearm (Meyers 1992; Vazquez 1994).

The high safety factor in wing function (over-secured wing function) via bone- and ligament-based automatic operation also implies the significance of biomechanical automatism. Moreover, Dial (1992) proposes that the only reason for the evolutionary retention of the forearm muscles in birds is the fact that those muscles are needed for modification of the shape of the wing during periods of nonsteady flight. He suggests also that forelimb muscles in most birds are not essential for normal extension and

flexion of the wing during each wing beat and consequently significant metabolic savings may be enjoyed by birds that undertake frequent and prolonged periods of level flapping flight since the metabolic costs required to operate the avian locomotor apparatus would be reduced.

Operation in bats

Bats have very long forearm that is dominated by the radius whereas the ulna is reduced to a thin, rod-like bone which terminates before reaching the half of the radius. According to Hill and Smith (1984), bats have also reduced their forearm muscles to overcome the problems associated with having large distal wing muscles and extra weight; in return for this they have built in a tendino-muscular automatic system for extending the dactylopatagium (flight membrane spanning digits 2–5). The extensor muscles, *m. extensor carpi radialis longus et brevis* are highly inelastic and tendinous, and they automatically pull on the distal wing with very limited overall muscle power when the

elbow is extended. The antagonist *m. flexor carpi ulnaris* has a similar construction and therefore functions also automatically: when the elbow is actively flexed, the tendon of this muscle pulls on the fifth metacarpal and thereby partially collapses the dactylopatagium (Hill and Smith 1984; see Figure 4). No species are directly referred to in the description of Hill and Smith; they generalise this structure as being characteristic for 'bats'. Norberg (1972), however, describes a very robust-bellied *m. extensor carpi radialis longus et brevis* in dog-faced bat *Rousettus aegyptiacus*. Vaughan's (1959) description lies somewhere between the two stating that the *m. extensor carpi radialis longus et brevis* in *Eumops*, *Myotis* and *Macrotus* bats are large muscles and both has a strong fascial covering; a feature that can correspond to the tendinous structure of these muscles described by Hill and Smith (1984). In any case, in addition to *m. extensor carpi radialis longus et brevis* there are locking mechanisms and ligaments of the carpus of bats that contribute to keep the hand wing outstretched (Norberg 1969).

Summing up, the enormous energetic cost of powered flight favours the evolution of an automatic mechanism, which

- (1) helps diminish weight and inertia in the wing by eliminating the need for extra muscles (Norberg 1990; Dial 1992; Vazquez 1994);
- (2) functions to automate the complex internal kinematics of the wing during flapping flight (Vazquez 1994); and
- (3) functions to ensure that flying animals will comply with the demand of powered flight which requires the forearm to extend and flex in coordination with the manus and carpus (Vazquez 1994).

Upon these energetic and mechanical constraints acting on flying animals, it is reasonable to assume the existence of an automatic mechanism in pterosaurs, as well, that brings and holds the wing finger in extended position while preventing the full extension of the elbow and thus sparing the energy of muscle work and neural control to achieve this. Nevertheless, the potential of pterosaur wings to function automatically at least to a certain extent has never been evaluated in detail before.

Overview of pterosaur wing anatomy

The wing spar of pterosaurs consists of the forelimb bones with a number of significant morphological modifications including elongation, reduction, fusion and complete loss of certain elements. Although there are considerable differences in the shape of bones, range of movements within the joints and consequently in the construction and function of the wing among taxa, a general overview of the flight apparatus of pterosaurs can be given (for more detailed description see e.g. Bramwell and Whitfield 1974;

Wellnhofer 1978; Bennett 2001; Chatterjee and Templin 2004; Wilkinson 2008).

The shoulder girdle is composed of the fused scapulocoracoid, the glenoid fossa of which is saddle-shaped allowing pro- and retraction, elevation and depression as well as rotation of the humerus along its long axis. The humerus (Figure 5. 'Hu') has a prominent deltopectoral crest which, in the gliding position of the extended wing, either points cranio-laterally (e.g. in *Rhamphorhynchus*, *Dorygnathus* or tapejarids) or curves ventrally (e.g. in anhanguerids). The distal articular condyles, similarly to those of birds, permit the radius and ulna to be moved only in the plane of the wing, but the range of this movement is wide. The antebrachial bones (Figure 5. 'Ra' and 'Ul') are long, almost equal in length and lie close to each other. Their proximal and distal ends expand abruptly. The ulna has no olecranon process on its proximal end. The radius is generally slender compared to the ulna and able to slide somewhat along the long axis of the ulna during elbow flexion. The carpal region consists of three carpals and of a unique pterosaur wrist bone, the pteroid. The proximal and distal syncarpals are composed of the fused two and three proximal and distal carpals, respectively. Their general shape is complex allowing only a limited sliding movement possible in both the antebrachial-proximal syncarpal and in the intersyncarpal joints (Figure 5(B)). The preaxial carpal (also called medial carpal) articulates on the anterior surface of the distal syncarpal. There is a pit on its anterodorsal surface within which a rounded sesamoid bone was located (Sesamoid A, *sensu* Bennett 2001; Figure 5(A)). The pteroid is an elongate, rod-like element (Figure 5. 'Pt'), the attachment point and orientation of which have been the subject of heated debates. It has been suggested that the pteroid was directed medially and that the dorsal pit of the preaxial carpal was the articular surface for the pteroid (Bramwell and Whitfield 1974; Padian 1984). Later Bennett (2001) pointed out that the concerned dorsal pit was occupied by a sesamoid and therefore was unfit to serve as an articular facet for the pteroid. He suggested instead that the pteroid articulated to the side of the preaxial carpal. Concerning its relative position some authors have postulated an anteriorly facing pteroid based on the suggested higher aerodynamic efficiency of a larger propatagium (Frey and Riess 1981; Wilkinson et al. 2006; Wilkinson 2008). This reconstruction has been strongly challenged, since articulated fossil specimens always show medially directed pteroid and the delicate nature of it also makes unlikely that the pteroid could bear the loads coming with the anteriorly directed position (Frey et al. 2006; Bennett 2007a). Here we prefer the medially directed position of the pteroid, too. The metacarpus of pterosaurs is highly modified. Metacarpals I–III are slender or even partially reduced in length losing their contact to the distal syncarpal. Metacarpal IV (called the

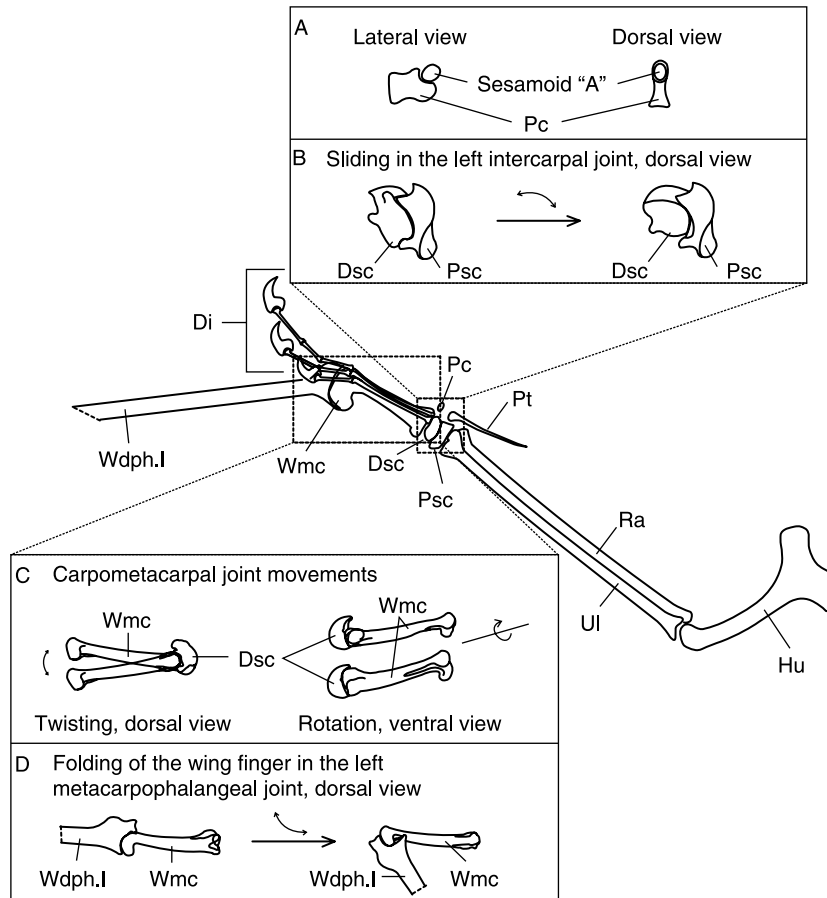

Figure 5. Schematic line drawing of the wing bones of pterosaurs represented by a *Rhamphorhynchus*. Note the relevant distal joint movements in the magnified pictures (A)–(D). Only the proximal part of the first wing phalanx is presented here. Abbreviations: Di: manual digits; Dsc: distal syncarpal; Hu: humerus; Pc: preaxial carpal; Psc: proximal syncarpal; Pt: pteroid; Ra: radius; Ul: Ulna; Wdph.I: phalanx I of the wing digit; Wmc: wing metacarpal.

wing metacarpal), however, became very robust to support the enormous wing finger distally. Metacarpal V is lost. There is a very limited craniocaudal twist and rotation of the wing metacarpal on the distal syncarpal (Figure 5(C)). The metacarpophalangeal joint is a hinge joint which allows the wing finger to be moved only in one plane that is almost the wing plane but has a slight dorsal component in flexion (Figure 5(D)). Whereas the clawed manual digits I–III are small and probably do not have any flight relevant role, digit IV, the actual wing finger, is hyperelongated and has four phalanges with immobile interphalangeal joints (except anurognathids, see below). Digit V is lost.

Previous suggestions and functional comparison with birds

Several suggestions relating to the functional background of wing movements in pterosaurs have been published in recent decades (Wellnhofer 1991; Bennett 2003a; Chatterjee and Templin 2004; Frey et al. 2006; Bennett

2007a, 2008; Wilkinson 2008). However, they failed to examine the issues surrounding the energetic requirements of manipulating the enormous wing finger, thus to consider how massive the forearm muscles required to do this work (Frey et al. 2006; Bennett 2007a, 2008). Although the notion of automatism in pterosaur wing function has been proposed by Wellnhofer (1991), his anatomical description is ambiguous and thus can be misleading. He reported a mechanism of automatism in the wing folding of pterosaurs that has been linked to that of birds. Pterosaurs have been compared to birds on the following principle:

‘...when the wing was folded, the radius was pushed distally along the ulna. When the radius was moved in this way it pressed on the proximal carpal, which twisted and slid away over a protrusion on the ulna. This caused the wing metacarpal to swing back, and with it the wing finger. Thus, in pterosaurs there was automatic folding of the wing, a principle with which we are familiar in birds. It means that when the wing was folded, the hand was automatically bent backwards in the wrist.’ (Wellnhofer 1991, pp. 53–54)

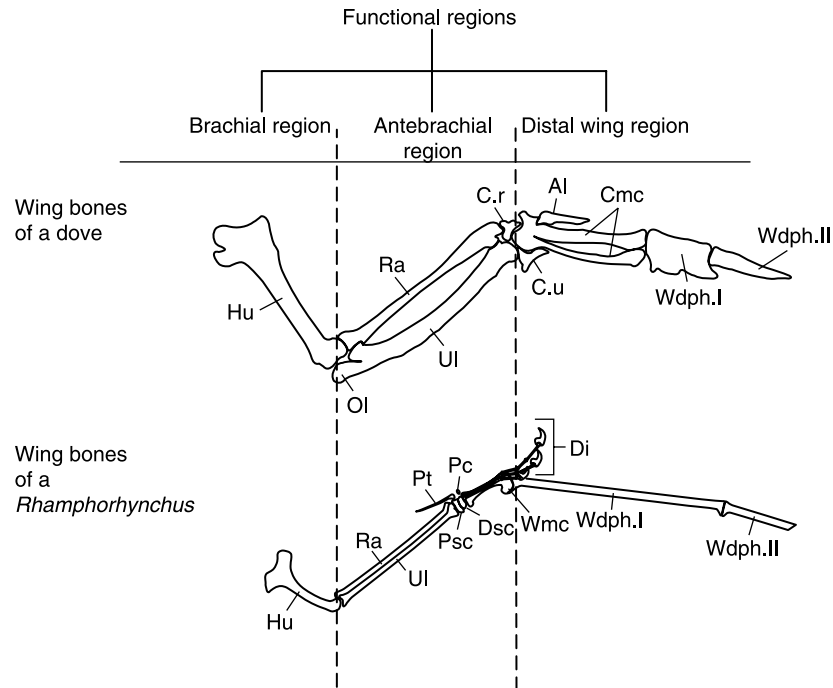

Figure 6. Functionally analog regions in the wings of birds and pterosaurs represented by a dove (*Columba livia*) and a *Rhamphorhynchus muensteri*, respectively. Note that the distal pivot also responsible for the automatism in the bird wing is between the forearm and distal wing regions, whereas the 'antebrachial region' in pterosaurs consists not only of the forearm bones but the carpus and metacarpus are also involved, so as they cannot provide the same automatic function in pterosaurs as they do in birds. Abbreviations: Al: alula; Cmc: carpometacarpus; C.r: carpi radiale; C.u: carpi ulnare; Di: manual digits; Dsc: distal syncarpal; Hu: humerus; Ol: olecranon process; Pc: preaxial carpal; Psc: proximal syncarpal; Pt: pteroid; Ra: radius; Ul: Ulna; Wdph.I–II.: phalanges I and II of the wing digit; Wmc: wing metacarpal.

It is clear, that this functional description was based on the mechanism of the 'drawing-parallels' in the wings of birds. However, it remains uncertain what exactly is meant by 'folding the wing'. The term 'wing folding' should be applied to the complete folding of the wing including the flexion of all functional regions, and does not refer to the process of the folding but to the resulted flexed position of the wing. In case of pterosaurs this term has to explain the mechanism of the humeral adduction and the maximal flexion of the elbow, wrist and metacarpal–wing finger joints. The problematic phrase used by Wellnhofer of a 'backward swinging metacarpal and wing finger' in this context conveys the impression of complete wing folding. If this was the case, the wing bones of pterosaurs should be mechanically connected to complete the automatic wing folding in the same way as in birds, where the elbow-movement results in flexion–extension of the distal wing via passive bone-linkage. If this was possible in the pterosaur wings, too, it would raise the following questions:

- (1) How would the distal syncarpal and the wing metacarpal react to the twisting and sliding movement of the proximal syncarpal? What would be the resulted motion of the distal syncarpal and the wing metacarpal and could

this motion be performed automatically?

- (2) How would the wing finger react to the movement of the wing metacarpal in such an action? Could it swing back automatically as a result?

To answer these questions we must have a closer look at the functionally analogous wing bones of birds and pterosaurs first (see Figure 6).

The functional role of humerus, radius and ulna is very similar in both birds and pterosaurs (in terms of the hinge joint where movement can only occur in one plane; Bramwell and Whitfield 1974; Bennett 2003a; Frey et al. 2006), thus they are considered here as functional analogues with the humeri belonging to the brachial, the radius/ulna to the antebrachial region of the wing. The proximal pivot of the wings of both birds and pterosaurs is located in the elbow joint. The proximal carpals of birds consist of two well separated bones (radiale, ulnare), whereas the distal carpals are fused to the metacarpus forming the carpometacarpus. The distal pivot of the wings of birds is found between the antebrachial bones and the carpometacarpus; accordingly all wing elements distal to this joint belong to the distal wing region (the carpometacarpus along with the fused wing fingers and primary feathers). The separated position of radiale and

ulnare (radiale is cranially, ulnare is caudally, see Figure 6) is of great importance concerning the automatic flexion–extension of the wing. The arrangement and movement ranges of the homologous bones and joints in pterosaurs are quite different to that of birds (see above), thus they cannot be considered as functional analogues. Since pterosaurs have only a restricted movement range in the wrist joints compared to the metacarpophalangeal hinge-joint (Figure 5(D)), we can assume that the carpus and metacarpus of pterosaurs were rather the part of the analog ‘antebrachial region’ of birds than that of the ‘distal wing region’ (Figure 6). In birds all the elements of the ‘distal wing region’ form the functional analog of the wing finger in pterosaurs. Thus, whereas the distal pivot is found between the forearm, proximal carpals and the carpometacarpus in birds, this flexible joint in pterosaurs is obviously between the wing metacarpal and the first phalanx of the wing finger (see Figures 5(D) and 6). These significant differences in the arrangement and function of the homologous bones of pterosaurs and birds do not support the idea of a comparable automatic wing folding mechanism.

The next question to consider is whether there was a different type of passive bone-linkage present in pterosaur wings that would cause automatic wing flexion. Earlier authors such as Hankin and Watson (1914) or Bramwell and Whitfield (1974) as well as recent ones (e.g. Bennett 2001; Wilkinson 2008) described the possible movements in the elbow and wrist joints and their consequences regarding other wing bones in *Pteranodon* and *Anhanguera*, yet none noted any effect of them resulting in the automatic folding of the wing finger. Bramwell and Whitfield (1974) declared that the possible movements between the elbow, forearm and proximal syncarpal were mechanically connected but the movements in the joints distal to the proximal syncarpal were independent actions, not necessarily related to any other movement. Although they reconstructed a somewhat overextended wrist joint, this mistake does not affect the validity of the absence of an automatic wing finger folding. According to our current knowledge about these bones and the joint mechanics between them (Wellnhofer 1978, 1991; Bennett 2001; Chatterjee and Templin 2004; Wilkinson 2008), we cannot predict any resulted movements in the distal joints caused only by the sliding of the radius and the resulted twisting of the proximal syncarpal (Bramwell and Whitfield 1974). Thus Wellnhofer’s description of the automatic wing folding is currently insufficient to explain how pterosaurs could have automatically folded up their wing finger against the body.

Following the example of birds, the relative importance and contribution of soft tissues to automatic systems cannot be left out of consideration, even in case of fossil animals. Palaeontological analyses of the influence of soft tissues in an operating biological system are of course highly

restricted by a general lack of soft tissues being preserved in the fossil record. It is very hard to say anything about the precise arrangement and function of muscles and other soft tissues in extinct vertebrates and with a clade like pterosaurs the issue is further complicated by the lack of extant descendants and an uncertain extant phylogenetic bracket (EPB; e.g. see Bennett 2007a for comparison). However, soft tissues (including muscles and ossified tendons) are known from a few fossils (e.g. the new specimen of *Anuroganthus ammoni* – Bennett 2007b), although these are exceptionally rare. Thus the incompleteness of the direct fossil evidence and the absence of extant relatives prevent to come to far-reaching conclusions about distinct muscle groups or ligaments. Nevertheless, using the presumed extant archosaur affinities of pterosaurs (crocodiles and birds) by applying the so called EPB method (Witmer 1995) to them and tracing muscle origin and insertion points with muscle scars on pterosaur bones, Bennett (2003a, 2007a, 2008) gave a detailed description of pterosaur pectoral and forelimb myology, and similarly Frey et al. (2006) provided reconstructions of some forearm muscles based primarily on avian anatomy. Despite the lack of direct evidence and extant descendants, speculations on the relative significance and role of soft tissues can still be undertaken based on energetic and biomechanical principles. In the case of pterosaurs a potential automatic wing folding mechanism must have involved soft tissues to a significant degree, as there is no indication of a bone linkage which could perform this action. It is also questionable whether we should search for an automatic wing folding mechanism instead of suggesting a model for an automatic wing *extension*. The latter proposal may be better supported for the following reasons that emphasize the importance of an extended wing finger during flight:

- (1) The entire wing including the wing finger must have been held extended during gliding or soaring which was probably the most frequently used flight strategy of large pterodactyls (Heptonstall 1971; Brower 1983; Hazlehurst and Rayner 1992).
- (2) Although there has been no formal attempt to reconstruct the pterosaurian flight stroke in details, larger pterosaurs are believed not to have flexed their wings completely during steady flight (Unwin 2005, pp. 187–188).
- (3) If pterosaurs had folded their wing finger completely during upstroke, the trailing edge of the wing membrane would have experienced undesired fluttering even if it had been stabilized by a special trailing edge structure suggested by Tischlinger and Frey (2002).
- (4) An automatic wing folding mechanism would simultaneously fold the wing finger during elbow flexion, hence it would not allow the limited wing

flexion restricted to the elbow joint during upstroke that might have been essential for pterosaurs to avoid trailing edge wing flutter. In contrast to this having the wing finger automatically extended along with the elbow joint would have no such disadvantages.

After considering the importance of the extension of the wing finger, the difficulties to achieve and maintain this posture have to be pointed out, as well. According to our current understanding of pterosaur anatomy there was technically no movement possible between the individual wing finger phalanges (with the possible exception of the basal anurognathids, Bennett 2007b), so they would have functioned as one long rod-like lever arm. This has significant consequences for pterosaurs during flight (see also Figure 7):

- (1) Significant profile drag must have acted on the wing finger during flight, mainly to fold it back against the wing metacarpal (Figure 7(A)). This phenomenon is well known in bats where the distal leading edge consisting of the second and third phalanges of the third digit is greatly exposed to the bending forces caused by the air stream (Norberg 1969, 1970).
- (2) Drag might have acted also on the proximal part of the pterosaur wing trying to extend the elbow joint (Figure 7(A)) as it does in birds and bats (Norberg

1970, Brown et al. 1995). It is very important for a flying vertebrate to maintain the angle of the elbow joint during flight because if the wing elements were allowed to outstretch completely in a straight line, the wing would be difficult to control (Brown and Cogley 1996). This danger could have been more significant in pterosaurs given that they did not possess an olecranon process on the proximal end of the ulna to prevent overextension of the elbow joint as in birds and other tetrapods.

- (3) The supposed trailing edge stabiliser structure and the elastic wing membrane itself must have been under tension when the wing was extended in order to avoid flutter and maintain a stable wing planform, and in this state they must have pulled the wing finger backwards with significant force, which the latter must have resisted (Figure 7(B),(C)). Thus this force has contributed to the effect of the profile drag. Norberg (1970) also argues that in pterosaurs and bats the wing membrane pulls at the lines of attachment during flight and that the strain is especially great on those skeletal elements constituting the leading edge of the hand wing, which stretches out the membrane. She also stated that the fourth digit of pterosaurs had to resist alone the bending forces caused by air resistance and by pull of the wing membrane (Norberg 1970).

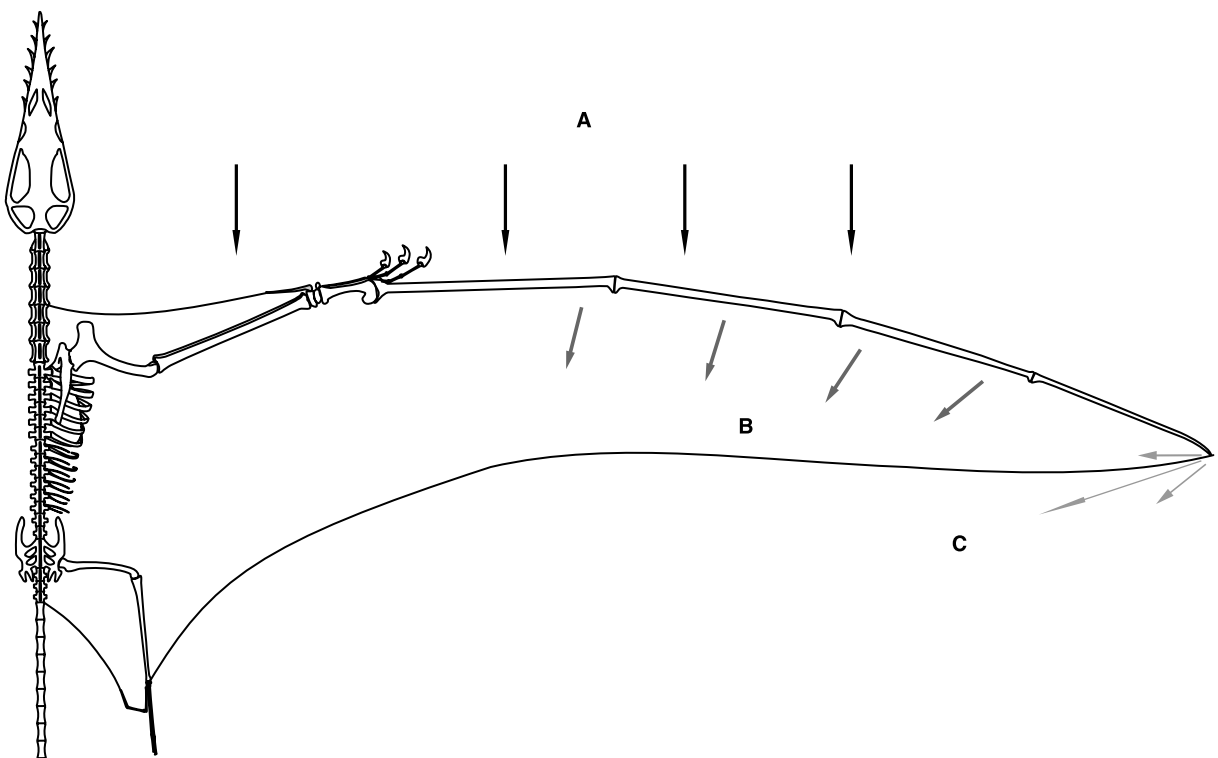

Figure 7. Forces with backward pulling effect on the wing finger. A, profile drag acting to extend the elbow joint and to fold back the wing finger (black arrows); B, tensile forces in the stretching brachioptagium (grey arrows); C, tensile forces in the stretching trailing edge structure (light grey arrows). The size of the arrows does not represent the relative magnitude of the forces.

Based on these factors one must consider the powerful forces acting on a pterosaur wing during flight that would have attempted to collapse the wing or straighten the elbow (potentially to a point of dislocation). These forces can be countered with either direct muscular force opposing them and/or with some kind of passive, automatic system. Apart from the mechanical, energetic and aerodynamical constraints, the form and relative position of the radius and ulna of pterosaurs also suggest that there was no considerable muscle mass in the forearm region to counteract these forces. The radius and ulna are long and slender and lie so close to each other that there is no significant space between them. Birds such as hummingbirds or pigeons, which have powerful muscles in this region, have robust radius and ulna bowing away from each other (see Figure 6). This arrangement indicates a significant amount of muscle mass associated with the antebrachium (Dial 1992). Albatrosses for example possess little forelimb musculature and have very slender forearm bones lying close to each other; an analogous form and arrangement as we can see in pterosaurs.

This argumentation is not to suggest that pterosaurs never folded their wings completely (including the wing finger) during flight but it is more likely that they might have used this option only for some maneuvers and terrestrial locomotion. In short, it must have been a much bigger energetic problem for pterosaurs how to bring and hold the enormous wing finger in an extended position during gliding and flapping flight than how to fold it occasionally. Since a bird-like or other type of bone-linkage construction cannot provide a model for an automatic wing extension in pterosaurs, other alternatives can and should be explored; namely models which operate with soft tissues mainly based on tendons and ligaments and only with limited muscle power.

Models proposed for pterosaurs

Under the assumption that an automatic wing extension mechanism was present in pterosaurs, the following section describes a hypothetical model for this built-in automatism. The models use birds as functional analogs for defining structures in the pterosaur wings which do not imply homology, but refer to the biomechanical function and topography in the case of ligaments and muscles, respectively. The terms *flexion* and *extension* are used here in their functional sense (see also Bennett 2008 for the issue of reversal of function in the distal arm of pterosaurs).

The lack of a bird-like bone-based automatism in pterosaurs, and the assumed reduction of dependency on musculature to extend the wing finger and hold it extended implies a primarily ligament-based system. Based on these assumptions it is reasonable to presume the presence of a ligamentous system in the propatagial region of pterosaurs

which, as a result of the elbow extension, automatically performs and maintains the extension of the wing finger during flight and prohibits the hyperextension of the elbow (Figure 8).

To extend the wing finger and prevent its folding against the drag and pulling effect of the stretching wing membrane during flight, this ligament or ligamentous network with some branches would need to originate on the cranial portion of the shoulder girdle or on the craniolateral surface of the humerus and insert on the cranial surface of the wing finger. Adequate origin and insertion areas respectively can be assigned to these relative positions in the pterosaur skeleton: the craniolaterally facing process of the pterosaur coracoid (referred to as 'biceps tubercle' by Padian (1983a) and as 'coracoid tubercle' by Bennett (2003a)) or the laterodorsal or lateroventral surface of the deltopectoral crest of the humerus for origin, and the extensor process or further along the cranial edge of the wing finger for insertion. It might also have had fascial insertion on certain skeletal muscles or on muscle tendons which have operated in the region of the shoulder girdle (such as *m. deltoideus*). The origin and insertion of the ligament are proposed here based on its supposed optimal biomechanical efficiency. Since the attachment scars on bones do not show how many structures (muscles, tendons and ligaments) attached to them, it is possible for us to co-opt the muscle scars identified by Bennett (2003a) to provide points of attachment for our models. Attachment scars that could be matched to the suggested origin of such a ligament are the scar on the coracoid tubercle of the scapulocoracoid and the extensive scars on the ventral and dorsal surface of the deltopectoral crest of the humerus identified by Bennett (2003a) as belonging to *m. coracobrachialis*, *m. pectoralis* and *m. deltoideus scapularis*, respectively. Similarly, the attachment scar on the extensor process of the first wing finger phalanx could reveal the insertion point of the ligament.

Even if there was a network of ligaments, a main ligament can be defined which would carry most of the loads and consequently accomplish most of the work. After its suggested primary function this ligament is referred to as *Ligamentum extensor digiti alae* (*LEDA*, Figure 8). To fulfill its biomechanical function and to permit minor corrections by independent muscle power, it should have been composed not only of collagenous tissue but also of a structure which was able to stretch and contract either actively represented by a muscle or passively represented by an elastic part of the ligament. Here the presence of an elastic part is preferred, which, as in birds (Brown et al. 1994), could have been stretched to approximately double its length and which would not have required any additional energy input to contract, in this case to return to its original shape. Based on the nomenclature applied for the histological description of

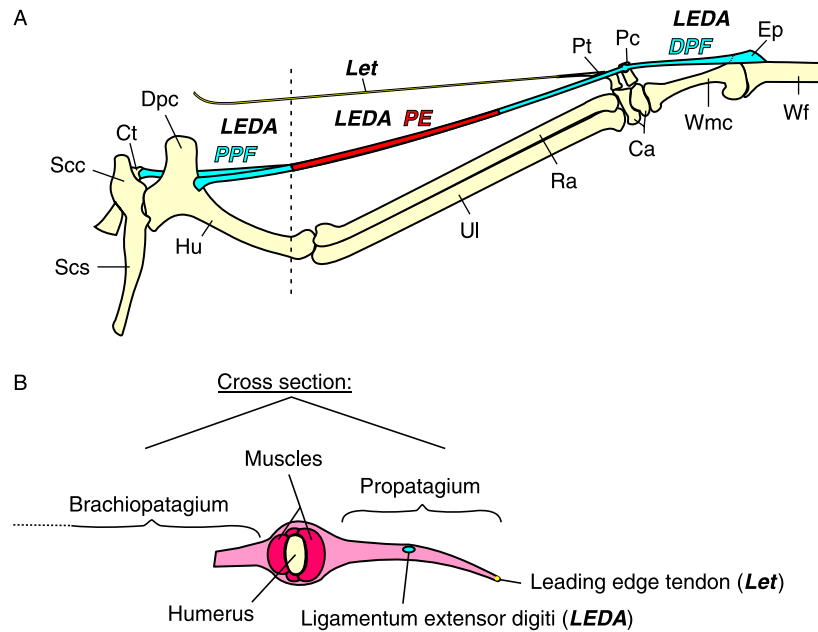

Figure 8. Schematic drawing of the position of *Ligamentum extensor digiti alae* (LEDA) and the leading edge tendon (*Let*) in the extended propatagial region of pterosaurs represented by a *Rhamphorhynchus*. (A) Dorsal view of the right shoulder girdle and proximal wing elements connected by LEDA and of the more anteriorly positioned *Let* showing its distal attachment to the pteroid. Only the referred structures are presented here. Note the histologically different segments of LEDA: PPF and DPF proximal and distal collagenous, fibrous segments, respectively (black); PE elastic middle section (dark grey). The branching of LEDA PPF shows the two possible origins. Due to the high number of possibilities the origin of *Let* is not shown. (B) Cross section in sagittal plane through the lower part of the brachium and propatagium showing the relative positions in schematic surrounding tissues in this region of the extended wing. Identification of the indicated muscles is ignored. Abbreviations: Ca: proximal and distal syncarpals; Ct: coracoid tubercle; Dpc: deltopectoral crest of humerus; Ep: extensor process on the proximal end of the first wing finger phalanx; Hu: humerus; LEDA PE: pars elastica of *Ligamentum extensor digiti alae*; LEDA PPF, DPF: proximal and distal pars fibrosa of *Ligamentum extensor digiti alae*; *Let*: leading edge tendon; Pc: preaxial carpal; Pt: pteroid; Ra: radius; Scc: coracoid of the fused scapulocoracoid; Scs: scapula of the fused scapulocoracoid; Ul: ulna; Wf: wing finger; Wmc: wing metacarpal.

LP in birds this medial segment is suggested to be defined as pars elastica (LEDA PE, Figure 8(A)) probably consisting of elastin-like complex; whereas the proximal and distal segments most likely composed of collagenous tissue should be referred to as pars fibrosa (LEDA PPF and DPF, respectively, Figure 8(A)). The distal tendinous pars fibrosa could have run through the pit in the dorsal face of the preaxial carpal, accordingly sesamoid 'A' must have belonged to the LEDA DPF (see Figures 5(A) and 8(A)).

While not part of the wing extension system itself as proposed here, it is perhaps worth commenting on the possible role of the pteroid in the pterosaurian forewing as this system would also have to integrate with the proposed automatic system and other soft tissues of the forelimb. The structure that could have controlled the camber of the propatagium is a tendon (Figure 8(A) and (B) 'Let') which has been suggested by other authors to be in the leading edge of the propatagium and to be connected to the pteroid (Figures 1 and 8(A) 'Pt'). In this position it could have cooperated with the medially directed pteroid on the cambering of the propatagium, on altering of the angle of attack and the shape and hence influencing flight

performance (Abel 1907, 1919; Wellnhofer 1975, 1978, 1982; Padian 1983b; Frey et al. 2006). As it was most probably a tendon, not a ligament, several muscles can come into consideration concerning its origin. It could have been the tendon of *m. pectoralis pars propatagialis* or that of a branch of caudal neck muscles such as *m. longus colli ventralis* or *mm. intertransversarii*. Not every author is of the same mind concerning the existence of a leading edge tendon. According to Bennett (2007a) there is no evidence of any attachment scars on the distal end of the pteroid, and thus he rejected the notion of a leading edge tendon.

According to the proposed model the muscular-ligamentous system of pterosaurs would function as follows:

- (1) When the wing is folded (humerus adducted, elbow, wrist and wing metacarpal-wing finger joints flexed by muscle power) the passive LEDA is loose and allows the wing finger to be held in this folded position by the flexor muscles not discussed here (Figure 9(A)).
- (2) When the wing is extended (humerus abducted and elbow and wrist extended by muscle power) and

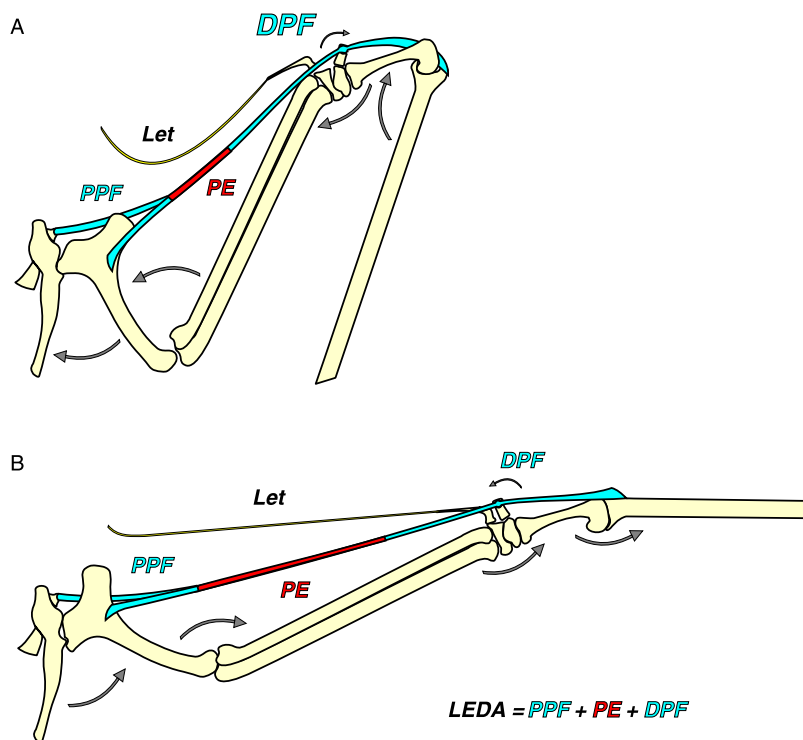

Figure 9. Operating principle of *Ligamentum extensor digiti* (*LEDA*) represented in a *Rhamphorhynchus* model without showing the involved muscles essential for completing the whole process (e.g. brachial muscles for elbow flexion). (A) When the wing is folded, *LEDA* is loose and passive with pars elastica (*PE*) adopting its minimal, relaxing length. (B) When the humerus is abducted and the elbow is extended by muscles not outlined here, *PE* and consequently the entire *LEDA* stretches to its maximal length (here *PE* approximately to double of its relaxed length, whereas the collagenous proximal and distal pars fibrosa [*PPF*, *DPF*] retain their length) and in this tense condition it pulls the wing finger cranially and holds it in this position until the beginning of a new elbow-flexion. Due to *PE*, different degree of elbow flexion means different level of tension in *LEDA*, which may have caused different level of wing finger extension (various degrees between the wing finger and the metacarpus). It can be seen in the pictures that the whole mechanism concerning *LEDA* is completed and maintained automatically. The arrows refer to the movement directions of different parts of the wing during flexion and extension. The smallest arrow suggests a very limited distally swinging movement of the preaxial carpal on the distal syncarpal during wing folding. Abbreviations: *LEDA*: *Ligamentum extensor digiti alae*; *Let*: leading edge tendon; *PE*: pars elastica of *Ligamentum extensor digiti alae*; *PPF* and *DPF*: proximal and distal pars fibrosa of *Ligamentum extensor digiti alae*.

therefore the distance between the origin and insertion of *LEDA* increases, the ligament elongates to its maximal length via the *pars elastica*, is put under maximal tension and as a consequence it simultaneously pulls the wing finger cranially to full extension and holds it in this position without the need for direct muscle force until the wing begins to be folded again. (Figure 9(B)).

Although the whole process is indirectly coordinated by independent flexor and extensor muscle groups of the brachium and antebrachium, the main load bearer in the wing finger extension is the *LEDA* itself, the biomechanical features of which are adequate to play this role in the function of the wing.

A bat-like tendinous antebrachial muscle construction (Figure 4) could also have operated in pterosaurs, although it would have been more difficult for them due to the bone

arrangement in the distal wing. Under this construction a tendon like this must have spanned four articulations (forearm–carpal, proximal syncarpal–distal syncarpal, carpal–metacarpus, metacarpus–wing finger, see Figure 5) and a significant distance (in case of elongated metacarpus in larger pterodactyloids) without any other anchoring before reaching its destination, namely the extensor process on the first phalanx of the wing finger. However, the preaxial carpal (Figure 5(A)) could have supported the tendon and could have kept it free from these joints. In this case such a tendinous structure derived from an extensor muscle (flexor in homologous sense *sensu* Bennett 2008) could have originated on the scar adjacent to the medial epicondyle of the humerus referred to as belonging to *m. flexor digitorum longus* by Bennett (2008). The insertion would have been also on the extensor process of the first wing phalanx. In fact, this tendinous muscle would correspond to the defined *m. flexor digiti quarti* (Bennett 2008) the name of which obviously refers

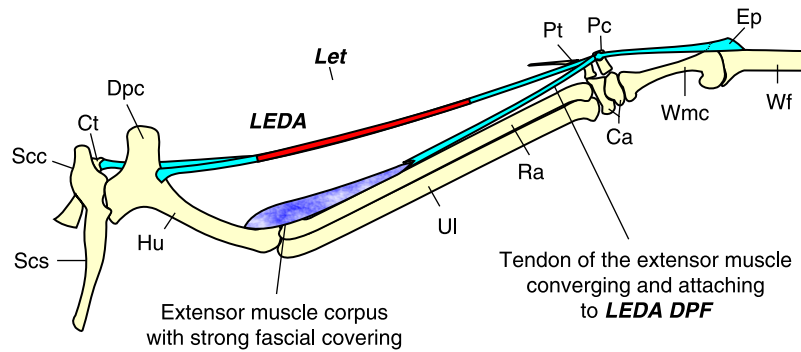

Figure 10. 'Hybrid-model' construction of a pterosaur with the combination of bird- and bat-like structures in the forewing. Bird-like automatic structure is the *LEDA* which corresponds to the *Ligamentum propatagiale* in birds; bat-like semi-automatic structure is the tendinous extensor muscle with expressed fascial covering in the forearm. The combined functioning of these two may lead to the biomechanically most efficient automatic wing extension in pterosaurs. Only the referred structures are presented here. For abbreviations see Figures 8 and 9.

to its homologous origin and not to its wing-extending function.

Due to its position and thereby improved leverage, the hypothesized *LEDA* would have been a biomechanically more efficient solution than a pure bat-like muscle construction. However, a combination of the two constructions might be just as useful, since *LEDA* and the tendinous extensor could have shared the loads to extend the wing finger. If the loads decrease on both elements, the need for a massive, robust propatagial ligament or antebrachial muscle could be reduced, respectively. In this case the tendon of the antebrachial extensor muscle with strong fascial covering might have converged and attached to the *LEDA DPF* before it reaches the preaxial carpal. Accordingly it would be a 'hybrid-model' construction consisting of bird- and bat-like structures that allows a limited muscle control simultaneously. (See Figure 10.)

Discussion

The models presented here are hypothetical in nature and based on the assumption that pterosaurs had an automatic wing extension apparatus in the arms. Clearly direct evidence for this is scant, but the presence of automatic mechanism in wing function in two wildly differently constructed flying vertebrates, in birds and bats, and the functional and energetic benefits of such a system suggest that a mechanism like this would be of great value to pterosaurs as well. Although using birds and bats as direct analogues to pterosaurs is of course problematic, pterosaurs clearly have aspects of their flight mechanics and anatomy in common with them both. The lack of an olecranon process or any other structure on the humerus or antebrachium to prevent the overextension of the elbow and the apparent absence of extremely large antebrachial muscles to resist drag forces on the long wing finger also

support the need for such a ligamentous system. Albatrosses for example possess little forelimb musculature and have very slender forearm bones lying close to each other; an analogue form and arrangement as we can see in pterosaurs. In this context it would be interesting to examine the robustness of *LP* and *LLC* in albatrosses, where in return for the reduced forelimb muscles one would expect that these ligaments are more developed than in birds with significant antebrachial muscles. However, the distal wing (carpometacarpus + wing digits + primary feathers) of albatrosses is a relatively short portion of the whole wing, so its function and control cannot be directly compared to the demands of operating the enormous wing finger of pterosaurs. Consequently the presence of a ligamentous system in the propatagial region described above may be along with a mainly tendinous, bat-like extensor muscle on the forearm is preferred here (Figures 8 and 10). This system could operate passively and automatically, does not require much space for attachment, does not need additional energy input over the normal tissue-maintaining energy, and let the muscles be busy only with the fine-tuning of movements during steady flight (gliding or flapping) or coordinate the wing during take off, manoeuvres or landing.

Direct supporting evidence for either of the two models presented here can potentially be identified in the fossil record (either from existing material or future finds). For example, the presence of a bat-like tendinous muscle in the antebrachium of pterosaurs might be confirmed by the study of the ossified tendons found in association with the radius, ulna and wing metacarpal in *Nyctosaurus* specimens (Bennett 2003b) and by the robust mineralised tendons found in association with the forearms of *Muzquizopteryx coahuilensis* (Frey et al. 2006). However, the mineralised tendon cranial to the radius in *Muzquizopteryx* has been referred to as the remnant of *musculus extensor metacarpi radialis* and not

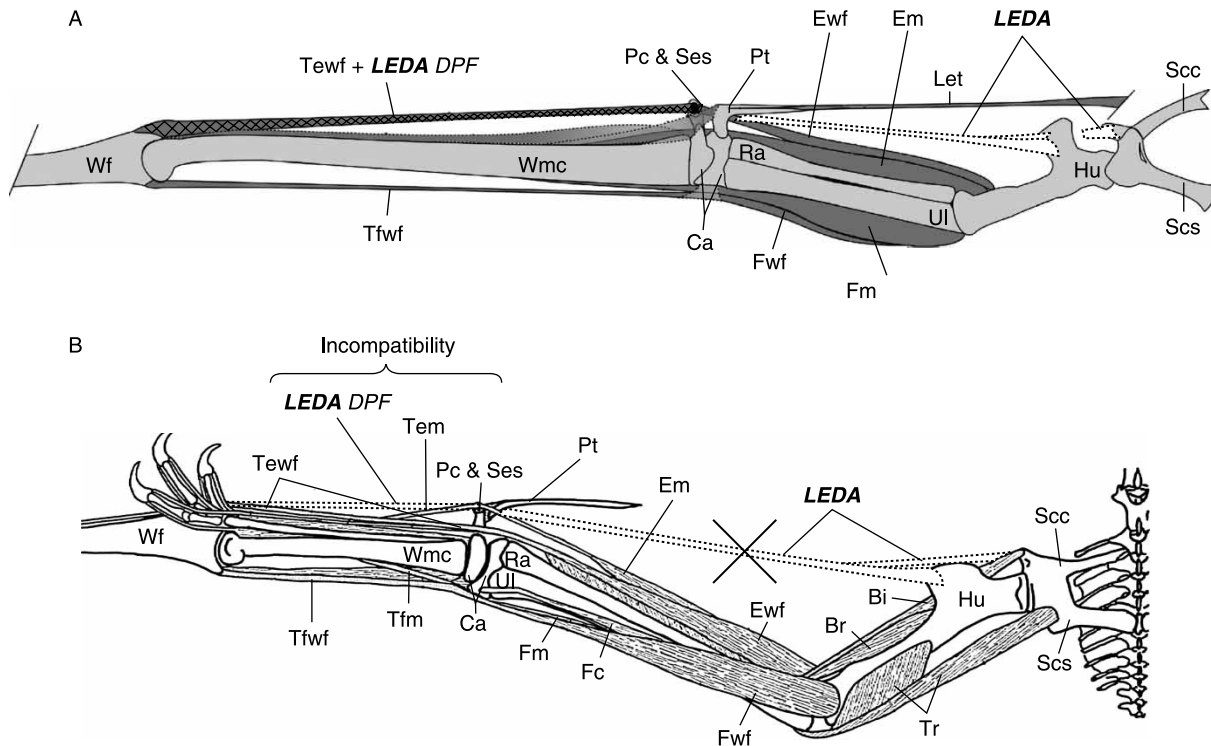

Figure 11. Adoption of the first model to the forelimb musculature reconstruction of (A) Frey et al. (2006) and (B) Bennett (2008). All referred flexor and extensor muscles are used in their functional sense. Note that due to the differences in the interpretation of muscles in the two reconstructions, a simplified nomenclature is used here for most of the flexors and extensors. (A) The reconstruction of Frey et al. is compatible with the basic wing extension model as it allows the *LEDA* to become confluent with the tendon of the wing finger extensor muscle so that the united ligament and tendon pass through the preaxial carpal together and attach on the extensor process of the first wing phalanx. (B) The reconstruction of Bennett is incompatible with the suggested model since the preaxial carpal is occupied by the tendon of the wing metacarpal extensor muscle thus it interferes *LEDA* to pass through the preaxial carpal to be kept away from the wrist. Abbreviations: Bi: *m. biceps*; Br: *m. brachialis*; Ca: proximal and distal syncarpals; Em: extensor of the wing metacarpal; Ewf: extensor of the wing finger; Fc: flexor of the carpals; Fm: flexor of the wing metacarpal; Fwf: flexor of the wing finger; Hu: humerus; *LEDA DPF*: distal pars fibrosa of *Ligamentum extensori digiti alae*; Let: leading edge tendon; Pc: preaxial carpal; Pt: pteroid; Ra: radius; Scc: coracoid of the fused scapulocoracoid; Scs: scapula of the fused scapulocoracoid; Ses: sesamoid of the preaxial carpal; Tem: tendon of the extensor of the wing metacarpal; Tfwf: tendon of the flexor of the wing finger; Tfm: tendon of the flexor of the wing metacarpal; Tr: *m. triceps*; Ul: ulna; Wf: wing finger; Wmc: wing metacarpal. (Figures modified from (A) Frey et al. 2006 and (B) Bennett 2008).

as belonging to the wing finger extensor system. Even so, it is still possible that the tendon labeled as *m. extensor metacarpi radialis* by Frey et al. (2006) could actually correspond to the tendinous wing finger extensor muscle, though the actual origin and insertion are ambiguous.

The proposed models for pterosaur wing extension have to fit with the available information on the pterosaur forelimb. However, little has been published on the reconstruction of flight relevant muscles of pterosaurs, therefore it is very important to attempt to reconcile the few previous reconstructions with the new model, with key papers by Short (1914), Frey et al. (2006) and Bennett (2003a, 2007a, 2008).

There are apparent topological similarities between the proposed model and a much earlier, though largely overlooked reconstruction by Short (1914) concerning the

origin and insertion of the extensor of the wing digit. He reconstructed the extensor muscle ('knuckle extensor muscle') as originating from along the side of the humerus from deltopectoral crest to the lateral epicondyle and inserting on the extensor process of the first wing phalanx. Although the line of force acting on the wing finger is very similar to that of the proposed models, the very automatic function is lost in Short's reconstruction as it instead assumes a huge muscle mass on the humerus to operate the wing finger extension.

One of the most recent reconstructions how this region of the wing could have functioned in pterosaurs was proposed by Frey et al. (2006). In this paper they described parts of the forearm muscles, tendon remains and a sesamoid ('Sesamoid A', Bennett 2001; see Figure 5(A)) which is usually found in the pit of the preaxial carpal in Cretaceous pterodactyloid pterosaurs. They assumed that

the *musculus extensor digiti*, which operated the wing finger extension, originated on the distal part of the humerus and inserted on the prominent process of the first wing finger phalanx. According to them the tendon of *m. extensor digiti* passed the carpus through the pit of the preaxial carpal and inserted on the extensor process of the first wing finger phalanx. However, there is no trace of direct connection preserved between the forearm and the attached mineral fibres of the preaxial carpal-sesamoid complex. They postulated that the cranially pointing preaxial carpal with the sesamoid served as a pivot which kept the tendon of *m. extensor digiti* away from the arm. They also suggested that the pteroid bone could have served as an attachment area for propatagial tensor muscles and presumed that this muscular-tendinous system could have had a role in supporting and controlling the propatagium and even in the extension of the wing (Frey et al. 2006). Our models do not contradict this concept but rather complement it with an additional system that passively cooperates with the active muscle system in the wing function. Considering the first model *LEDA* could originate and insert on the described areas (see Section 4.3) with the prerequisite that the tendon of *m. extensor digiti* converges with the distal portion of the ligament and they pass through the preaxial carpal as a united tendon to reach their destination, the extensor process of the first wing phalanx. Thus *LEDA* could passively extend the wing finger simultaneously with active elbow extension, whereas *m. extensor digiti* would be responsible for the active fine manipulation of the wing finger (see Figure 11(A)). The second model can be set in the same way with the additional assumption that the ossified tendon referred to by Frey et al. (2006) as belonging to *musculus extensor metacarpi radialis* actually could have been remnants of the tendinous *m. extensor digiti*. Hence an additional semi-automatic structure, the tendinous *m. extensor digiti* would further decrease the energy output and increase the efficiency of extension of the wing finger.

In contrast, Bennett (2007a, 2008) argued that the preaxial carpal-sesamoid complex supported the tendon of *musculus flexor carpi ulnaris* (flexor in homological sense, extensor in functional sense) that originates on the distal end of the humerus just above the ulnar and radial condyles and inserts on the anterior surface of the medial shaft of the wing metacarpal. He indicated that, due to the limited motion range of the preaxial carpal, it would not be able to accommodate the greater range of movement of a wing finger extensor tendon, however, he did not specify to support his argument what this suggested motion range would be for the wing finger extensor tendon and for the tendon of *musculus extensor carpi ulnaris*, respectively. Thus Bennett (2008) reconstructed the tendon of *m. flexor digiti quarti* (wing finger extensor in functional sense) as running on the cranial surface of

the wrist to the first wing phalanx without any structure that could keep it away from the wrist joints. This set-up contradicts our models, since the preaxial carpal has been excluded from the wing finger extension process. The integration of the preaxial carpal in both wing extension models is of crucial importance since it provides the distal pivot for *LEDA* in the first model and for the united *LEDA* and tendon of the wing finger extensor (functional sense) in the second model while keeping them away from the wrist. Without the preaxial carpal *LEDA* could have functioned only with significant decrease in efficiency, whereas the extensor muscle of the wing finger could possibly not have overcome the arising problems. Thus Bennett's reconstruction is incompatible with the wing extension models presented here (see Figure 11(B)).

Further problems are raised by Bennett's (2001, 2007a, 2008) reconstruction of the pteroid articulating to the side of the preaxial carpal, although this idea is contradicted by the fossil record. In addition to the lack of fossils with the pteroid articulating to the preaxial carpal, in some exceptionally well preserved fossils (among others in the type specimen of *Pterodactylus antiquus*, *Anhanguera santanae* AMNH 22555, *Rhamphorhynchus 'longicaudus'* BSP 1877 X1, *Pterodactylus kochi* BSP 1937 I 18a, etc.) the pteroid points medially while the preaxial carpal lies almost always on its side being pulled distally by a structure into which it was most probably incorporated (Elgin and Frey 2008). This bone arrangement suggests that the pteroid was connected to a structure which held it directed medially during decay, whereas the preaxial carpal was part of a construction that pulled it distally during diagenesis. This is inconsistent with the notion that both belonged to the same functional unit, as it would be required if the pteroid had tightly articulated to the side of the preaxial carpal as reconstructed by Bennett (2001, 2007a, 2008). Furthermore in fossils with intact wrist articulations the preaxial carpal would not have been pulled distally if the tendon passing it over had attached to the wing metacarpal. It is more parsimonious to conclude that the tendon attached on the wing finger which was folded and consequently pulled the preaxial carpal distally during the decay. Although it contradicts Bennett's (2007a, 2008) reconstruction this interpretation fits well with our models. In fact, a possible taphonomical reason for this pattern can also be given based on the models: during the decay, the elastic part of the hypothesized *LEDA* or the muscle segment of a tendinous extensor muscle would decompose earlier than the ligamentous/tendinous segments of these structures. Consequently the folding of the wing finger would pull the preaxial carpal distally since it has no proximal anchoring left which could hold it *in situ*. Moreover in Bennett's (2007a, 2008) reconstruction it seems odd to have such a prominent device as the preaxial carpal to keep a tendon away from the wrist that inserts

again almost immediately behind the preaxial carpal on the wing metacarpal. If it had been the case, what could have kept away the extensor of the wing finger from all the joints it must have passed by? It is more reasonable to assume that the most suitable structure for that purpose must have been the modified, prominent, anteriorly facing preaxial carpal. In the new models the preaxial carpal could have served for leading the fibrous part of *LEDA* and the tendon of the extensor muscle along the elongated metacarpus to the first wing finger phalanx without attaching to the wing metacarpal.

The presence of a sesamoid was also described in the *LP* of birds (Meyers 1992; Brown et al. 1994), and has topographically a similar position as the preaxial sesamoid in pterosaurs. Brown et al. (1994) showed that a sesamoid bone can be seen in the distal part of *LP* pars fibrosa. Although they do not declare the function of this sesamoid, in any case it refers to the presence of a strong ligament or tendon. The topographical similarity of the sesamoid in birds and pterosaurs could also support the hypothesized relative position of *LEDA* in the models.

Although there is only circumstantial evidence of the presence of such propatagial ligament system currently available in pterosaur fossils, neither is there anything which directly contradicts it. Traces of such a thick, tough ligament in cases of fossils with otherwise excellent soft part preservation (such as *Jeholopterus*) might be expected but in general tendons and ligaments in the fossil record are exceptionally rare, with even those that might be considered large and robust and have the potential for preservation not being recovered. In fact most vertebrate groups have very tough tendons and ligaments operating in the regions of metapodium and digit phalanges for example, yet none of the pterosaur fossils show these clearly although they must have been present. Bennett (2000) has similarly noted that in most cases there is no direct evidence of distinct muscle or ligament attachment scars associated with the interphalangeal joints of the wing finger. Nevertheless, he declares that all pterosaurs are likely to have had large, strong collateral ligaments in that region based on their assumed mechanical importance. Most notably, in examples where both bones and cartilage are preserved, tendons and ligaments (though they would have formed part of the preserved complex) are not (Schwarz et al. 2007). This is further indication that tendons and ligaments are simply exceptionally rare (if unossified) to the point that they are effectively absent. The authors are unaware of any non-ossified tendons or ligaments in the archosaurian fossil record.

In addition to the energetic consideration the pteroid could provide further indirect evidence of a structurally complex, ligamentous propatagium. If the propatagium had only been a thin sheet of skin, it would probably not

have had the strength or integrity to incorporate a bone like the pteroid which can be fairly prominent in some cases (e.g. in *Nyctosaurus*), since bones are generally surrounded by complex soft tissues in which they are embedded.

Summary and conclusions

Two hypothetical models have been suggested here as to how the wing finger could have been extended in pterosaurs. These emphasize the significance of built-in automatism via a propatagial ligamentous and/or tendinous muscle system. These models are primarily based on considerations of energetics and flight mechanics and they fit well with the hitherto known anatomy of pterosaurs. The first model suggests a ligament that runs from the shoulder girdle or humerus to the wing finger and with the extension of the elbow it automatically pulls the wing finger in extended flight position. The second model is derived from the first but it is modified by the addition of a tendinous extensor muscle, so that they can share the loads of the automatic wing finger extension. Consequently neither the ligament nor the antebrachial extensor muscle must be as robust as they would have to be without each other to fulfil their task. Thus these models provide a new approach of the mechanism of wing operation in pterosaurs.

Concerning the recent reconstructions of distal wing muscles and their operation the new models are reconcilable with the concept of Frey et al. (2006) but inconsistent with that of Bennett (2007a, 2008) with respect to the arrangement of ligaments with the carpals. Hitherto there is no direct evidence (soft tissue preservation) in the fossil record which could support the models suggested in this paper, but a structurally complex propatagium with ligaments and tendinous structures could have embedded a bone like the pteroid and could have resulted in the flexed elbow position most commonly found in articulated specimens.

It has not been suggested here that there was no muscle force acting on the wing finger of pterosaurs to extend it but it can be assumed that such muscles as the *m. extensor digiti sensu* Frey et al. (2006) or the *m. flexor digiti quarti sensu* Bennett (2008), if they were not highly tendinous as in the second model, would have provided fine and more accurate regulation of the wing finger which would be necessary for subtle adjustments during flight, take off or landing.

The conception presented here is merely a hypothetical deduction based on recent analogues that respond to a similar biomechanical problem. Nevertheless, it can be assumed in pterosaurs that there is a functionally cooperating system consisting of passive ligaments and active muscles operating as a unit as they do in extant living organisms. These models can also be used as a

foundation for future research and as hypotheses that present new approaches for the anatomical, functional and mechanical reconstructions of pterosaurs.

Acknowledgements

The authors would like to thank S. C. Bennett for the critical comments on an earlier version of the manuscript and for access to his then unpublished work; the anonymous reviewer and M. Witton, for the thorough review and the helpful comments that significantly improved the standards of the manuscript; A. Ósi, G. Zboray and Corwin Sullivan for useful discussions; E. Frey for access to material in Karlsruhe; J. Pálffy for his technical advice and T. Tanács for the additional online animations. D. W. E. Hone is supported by grants awarded to Xu Xing by the Chinese Academy of Sciences.

Note

1. Email: dwe_hone@yahoo.com

References

- Abel O. 1907. Bau und Lebensweise der Flugsaurier. In: Verhandlungen der Kaiserlichen und Königlichen zoologisch-botanischen Gesellschaft Wien. p. 253–254.
- Abel O. 1919. Neue Rekonstruktion der Flugsauriergattungen *Pterodactylus* und *Rhamphorhynchus*. *Naturwissenschaften* (37):661–665.
- Baumel JJ. 1993. Handbook of avian anatomy: nomina anatomica avium. Publications of the Nuttall Ornithological Club, No. 23 2nd ed.
- Bennett SC. 2000. Pterosaur flight: the role of actinofibrils in wing function. *Hist Biol.* 14:255–284.
- Bennett SC. 2001. The osteology and functional morphology of the late cretaceous pterosaur *Pteranodon*. Part I. General description of osteology. *Palaeontographica*. A260:1–112.
- Bennett SC. 2003a. Morphological evolution of the pectoral girdle of pterosaurs: myology and function. *Evol Palaeobiol Pterosaurs*. p. 191–215.
- Bennett SC. 2003b. New crested specimens of the Late Cretaceous pterosaur *Nyctosaurus*. *Paläontologische Zeitschrift*. 77:61–75.
- Bennett SC. 2007a. Articulation and function of the pteroid bone of pterosaurs. *J Vertebrate Paleontol.* 27:881–891.
- Bennett SC. 2007b. A second specimen of the pterosaur *Anurognathus ammoni*. *Paläontologische Zeitschrift*. 81:376–398.
- Bennett SC. 2008. Morphological evolution of the forelimb of pterosaurs: myology and function. In: Buffetaut E, Hone DWE, editors. *Zitteliana Series B*, 28 (Special Volume: Flugsaurier: pterosaur papers in honour of Peter Wellnhofer). p. 127–141.
- Bergmann C. 1839. Über die Bewegungen von Radius und Ulna am Vogelflügel. *Archiv für Anatomie, Physiologie und wissenschaftliche Medicin*. p. 296–300.
- Bramwell CD, Whitfield GR. 1974. Biomechanics of *Pteranodon*. *Philos Trans R Soc Lond B*. 267:503–581.
- Brower JC. 1983. The aerodynamics of *Pteranodon* and *Nyctosaurus*, two large pterosaurs from the Upper Cretaceous of Kansas. *J Vertebrate Paleontol.* 3:84–124.
- Brown RE, Cogley AC. 1996. Contributions of the propatagium to avian flight. *J Exp Zool*. 276(112):124.
- Brown ER, Baumel JJ, Klemm DR. 1994. Anatomy of the Propatagium: The Great Horned Owl (*Bubo virginianus*). *J Morphol.* 219:205–224.
- Brown ER, Baumel JJ, Klemm DR. 1995. Mechanics of the avian propatagium: flexion–extension. Mechanism of the avian wing. *J Morphol.* 225:91–105.
- Chatterjee S, Templin RJ. 2004. Posture, locomotion and paleoecology of pterosaurs. *Geological Society of America. Special Paper* 376.
- Corvidae EL, Bierregaard RO, Peters SE. 2006. Comparison of wing morphology in three birds of prey: correlations with differences in flight behavior. *J Morphol.* 267:612–622.
- Dial KP. 1992. Avian forelimb muscles and nonsteady flight: can birds fly without using the muscles in their wings? *Auk* (4):874–885.
- Elgin R, Frey E. 2008. The problem of the pterosaur wrist. In: 6th Meeting of the European Association of Vertebrate Palaeontologists. Slovak Republic: Spisska Nova Ves. Volume of abstracts, p. 35.
- Elgin R, Hone DWE, Frey E. 2008. (in preparation). The nature and attachment of pterosaur wing membrane.
- Frey E, Riess J. 1981. A new reconstruction of the pterosaur wing. *Neues Jahrbuch für Geologie und Paläontologie. Abh* 161:1–27.
- Frey E, Buchy MC, Martill DM. 2003. Middle- and bottom-decker Cretaceous pterosaurs: unique designs in active flying vertebrates. In: Buffetaut E, Mazin JM, editors. *Evolution and palaeobiology of pterosaurs*. Geological Society, Special Publication. p. 267–274.
- Frey E, Buchy M-C, Stinnesbeck W. 2006. *Muzquizopteryx coahuilensis* n.g. n.sp. a nyctosaurid pterosaur with soft tissue preservation from the Coniacian (Late Cretaceous) of northeast Mexico (Coahuila). *Oryctos*. 6:19–39.
- Hankin EH, Watson DMS. 1914. On the flight of pterodactyls. *Aeronautic J.* 18:324–335.
- Hazlehurst GA, Rayner JMV. 1992. An unusual flight mechanism in the Pterosauria. *Palaeontology*. 35(4): 927–941.
- Heptonstall WB. 1971. An analysis of the flight of the Cretaceous pterodactyl *Pteranodon ingens* Marsh. *Scot J Geol.* 7:61–78.
- Hill JE, Smith JD. 1984. Bats. A natural history. British Museum (Natural History), Publication No. 877:53.
- McKritick MC. 1985. Myology of the pectoral appendage in kingbirds (*Tyrannus*) and their allies. *Condor*. 87:402–417.
- Meyers RA. 1992. Morphology of the shoulder musculature of the American kestrel, *Falco sparverius* (Aves), with implications for gliding flight. *Zoomorphology*. 112:91–103.
- Norberg UM. 1969. An arrangement giving a stiff leading edge to the hand wing in bats. *J Mammal.* 50(4):766–770.
- Norberg UM. 1970. Functional osteology and myology of the wing of *Plecotus auritus* Linnaeus (Chiroptera). *Ark Zool.* 22:483–543.
- Norberg UM. 1972. Functional osteology and myology of the wing of the dog-faced bat *Rousettus aegyptiacus*. *Zoomorphology*. 73(1):1–44.
- Norberg UM. 1990. Vertebrate flight. *Zoophysiology*. 27:209–211.
- Padian K. 1983a. Osteology and functional morphology of *Dimorphodon macronyx* (Buckland) (Pterosauria: Rhamphorhynchoidea) based on new material in the Yeal Peabody Museum. *Postilla*, 189.
- Padian K. 1983b. A functional analysis of flying and walking in pterosaurs. *Paleobiology*. 9:218–239.
- Padian K. 1984. A large pterodactyloid pterosaur from the Two Medicine Formation (Campanian) of Montana. *J Vertebrate Paleontol.* 4(4):512–524.
- Schwarz D, Wings O, Meyer CA. 2007. Super sizing the giants: first cartilage preservation at a sauropod dinosaur limb joint. *J Geol Soc Lond.* 164:61–65.
- Short GH. 1914. Wing adjustments of pterodactyls. *Aeronautic J.* 18:336–343.
- Solomon FV. 1993. *Lehrbuch der Geflügelanatomie*. Jena and Stuttgart: Gustav Fischer Verlag. pp. 102, 479.
- Tischlinger H, Frey E. 2002. Ein *Rhamphorhynchus* (Pterosauria, Reptilia) mit ungewöhnlicher Flughauterhaltung aus dem Solnhofener Plattenkalk. *Archaeopteryx*. 20:1–20.
- Unwin D. 2005. *The pterosaurs: from deep time*. New York: Pi Press. p. 187–188.
- Vaughan TA. 1959. Functional morphology of three bats: *Eumops*, *Myotis*, *Macrotus*. University of Kansas Publications, Museum of Natural History. 12:1–153.
- Vazquez RJ. 1994. The automating skeletal and muscular mechanisms of the avian wing (Aves). *Zoomorphology*. 114:59–71.
- Wellnhofer P. 1975. Die Rhamphorhynchoidea (Pterosauria) der Oberjura-Plattenkalke Süddeutschlands. *Allgemeine Skelettmorphologie. Palaeontographica. Abt. A* 148:1–33.
- Wellnhofer P. 1982. Zur Biologie der Flugsaurier. *Natur und Museum*. 112(9):279–291.
- Wellnhofer P. 1991. *The illustrated encyclopedia of pterosaurs*. 153. London: Salamander. p. 53–54.

- Wellnhofer P, Khun O. 1978. Handbuch der Paläoherpetologie. Teil. 19. p.17.
- Wilkinson MT. 2008. Three-dimensional geometry of a pterosaur wing skeleton, and its implications for aerial and terrestrial locomotion. *Zool J Linnean Soc.* 154:27–69.
- Wilkinson MT, Unwin DM, Ellington CP. 2006. High lift function of the pteroid bone and forewing of pterosaurs. *Proc R Soc B.* 273:119–126.
- Witmer LM. 1995. The extant phylogenetic bracket and the importance of reconstructing soft tissues in fossils. In: *Functional morphology in vertebrate paleontology*. New York: Cambridge University Press. p. 19–33.
- Witton MP. 2008. A new approach to determining pterosaur body mass and its implications for pterosaur flight. In: Buffetaut E, Hone DWE, editors. *Zitteliana Series B, 28 (Special Volume: Flugsaurier: pterosaur papers in honour of Peter Wellnhofer)*. p. 143–158.