

Pleistocene Chinese cave hyenas and the recent Eurasian history of the spotted hyena, *Crocuta crocuta*

GUI-LIAN SHENG,^{*†1} JULIEN SOUBRIER,^{†1} JIN-YI LIU,[‡] LARS WERDELIN,[§] BASTIEN LLAMAS,[†] VICKI A. THOMSON,[†] JONATHAN TUKE,[¶] LIAN-JUAN WU,^{*} XIN-DONG HOU,^{*} QUAN-JIA CHEN,^{**} XU-LONG LAI^{*} and ALAN COOPER[†]

^{*}State Key Laboratory of Biogeology and Environmental Geology, China University of Geosciences, Wuhan, Hubei 430074, China, [†]Australian Centre for Ancient DNA, School of Earth & Environmental Sciences, University of Adelaide, Adelaide, SA 5000 Australia, [‡]Key Laboratory of Evolutionary Systematics of Vertebrates, Institute of Vertebrate Paleontology and Paleoanthropology, Chinese Academy of Sciences, Beijing 100044, China, [§]Department of Palaeobiology, Swedish Museum of Natural history, Box 50007, S-104 05 Stockholm, Sweden, [¶]School of Mathematical Sciences, University of Adelaide, Adelaide, SA 5000, Australia, ^{**}Research Center for Chinese Frontier Archaeology, Jilin University, Changchun 130012, China

Abstract

The living hyena species (spotted, brown, striped and aardwolf) are remnants of a formerly diverse group of more than 80 fossil species, which peaked in diversity in the Late Miocene (about 7–8 Ma). The fossil history indicates an African origin, and morphological and ancient DNA data have confirmed that living spotted hyenas (*Crocuta crocuta*) of Africa were closely related to extinct Late Pleistocene cave hyenas from Europe and Asia. The current model used to explain the origins of Eurasian cave hyena populations invokes multiple migrations out of Africa between 3.5–0.35 Ma. We used mitochondrial DNA sequences from radiocarbon-dated Chinese Pleistocene hyena specimens to examine the origin of Asian populations, and temporally calibrate the evolutionary history of spotted hyenas. Our results support a far more recent evolutionary timescale (430–163 kya) and suggest that extinct and living spotted hyena populations originated from a widespread Eurasian population in the Late Pleistocene, which was only subsequently restricted to Africa. We developed statistical tests of the contrasting population models and their fit to the fossil record. Coalescent simulations and Bayes Factor analysis support the new radiocarbon-calibrated timescale and Eurasian origins model. The new Eurasian biogeographic scenario proposed for the hyena emphasizes the role of the vast steppe grasslands of Eurasia in contrast to models only involving Africa. The new methodology for combining genetic and geological data to test contrasting models of population history will be useful for a wide range of taxa where ancient and historic genetic data are available.

Keywords: ancient DNA, *Crocuta crocuta*, divergence time, evolutionary history, Northern China

Received 1 May 2013; revision received 21 October 2013; accepted 22 October 2013

Introduction

The Hyaenidae family arose in Eurasia in the Late Oligocene, about 25 million years ago (Ma), and reached a peak of diversity during the Late Miocene, about 7–8 Ma, totalling more than 80 fossil species from

Europe, Asia, Africa and North America (de Bonis 1973; Werdelin & Solounias 1991; Turner *et al.* 2008; Werdelin *et al.* 2010). The number of Hyaenidae species declined from the Late Miocene, eventually leaving only four extant species: spotted hyena (*Crocuta crocuta*), brown hyena (*Hyaena brunnea*) and aardwolf (*Proteles cristata*) in Africa; and striped hyena (*Hyaena hyaena*) in the Middle East, parts of southwest Asia and the Indian subcontinent. Although it is one of the smallest families of the Carnivora, living hyenas occupy a variety of habitat

Correspondence: Xu-Long Lai and Alan Cooper
E-mails: xllai@cug.edu.cn; alan.cooper@adelaide.edu.au
¹These authors contributed equally to this work.

types and fill a surprisingly wide range of ecological niches, and their presence is a useful indicator of ecosystem health (Turner *et al.* 2008). Among the four extant species, the spotted hyena, which is the sole member of the genus *Crocota*, has attracted considerable evolutionary and systematic interest due to having a social system similar to that of many primates, in contrast to other gregarious carnivores (Watts & Holekamp 2007; Diedrich 2008; Turner *et al.* 2008). Although currently restricted to sub-Saharan Africa, a variety of Late Pliocene and Pleistocene fossil spotted hyena species are recognized, including *Crocota dietrichi*, *C. eturono*, *C. honanensis*, *C. ultra* and the so-called 'cave hyenas' in the Far East (*C. crocuta ultima*) and Europe (*C. crocuta spelaea*) (Kurtén 1956; Diedrich 2008; Werdelin & Lewis 2008). However, the exact origin and evolutionary history of living spotted hyenas remains unresolved (Kurtén 1956, 1968; Turner 1984; Huang 1989; Werdelin & Solounias 1991; Markova *et al.* 1995; Jenks & Werdelin 1998; Werdelin 1999; Rohland *et al.* 2005; Koepfli *et al.* 2006; Watts & Holekamp 2007; Werdelin & Lewis 2008), as does the question of whether *Crocota* originated in Africa or Eurasia (Kurtén 1956; Turner 1990).

Ancient DNA provides a means to obtain direct evidence of the phylogenetic and population history of spotted hyenas, and has previously been used to show that the extinct Late Pleistocene cave hyenas in western Eurasia were nested within the diversity of living spotted hyenas (Rohland *et al.* 2005). The latter study, by Rohland *et al.*, proposes that the three mitochondrial clades found in Late Pleistocene cave/spotted hyenas from Europe and the Far East represent three separate dispersal events from an ancestral African population to Eurasia taking place between 3.5 and 0.35 Ma. However, the ages of the inferred dispersals (3.5 Ma to the Far East and 0.35–1.5 Ma to western Eurasia) appear considerably older than fossil data, which suggest much younger colonization dates for *C. crocuta* morphs in these areas. In Asia, the earliest fossil site for *C. crocuta ultima* (Zhoukoudian Locality 1 in China) is dated at 400–230 thousand years ago (kya) (Hu 1985; Liu 1999; Zhou *et al.* 2000; Shen *et al.* 2001; Qiu *et al.* 2004), while in Europe *C. crocuta spelaea* is first seen in western Eurasia around 300 kya (Baryshnikov & Tsoukala 2010), although another form with less certain relationships, *C. praespelaea*, had appeared in Spain by at least 780 kya (García & Arsuaga 2001). The discrepancy between molecular and palaeontological timescales suggests that the evolutionary history of spotted hyenas is not fully resolved, and further analyses are needed to reconcile the molecular and morphological data.

In China, *Crocota*-like hyena fossils have been found in more than 100 Pleistocene sites in 26 Chinese

provinces (Zdansky 1924; Qiu 1987; Ma & Tang 1992; Liu 1999; Tong 2007; Tseng & Chang 2007) and two morphological forms can be distinguished, *C. crocuta ultima* and *C. honanensis*. The latter is an early Pleistocene form, first detected in Henan Province, and morphological studies suggest it is a different species from the living spotted hyena *C. crocuta* (Kurtén 1956; Qiu 1987; Huang 1989). In contrast, *C. crocuta ultima*, which is known exclusively from the late Pleistocene, is considered either a standard *C. crocuta* or potentially an Asian subspecies (Kurtén 1956; Liu 1999; Tseng & Chang 2007). *C. crocuta ultima* became extinct around the end of the Pleistocene, that is, ~11.5 kya (Kurtén 1968; Liu 1999; Tong 2007; Tseng & Chang 2007), or potentially even as recently as ~7.8 kya (Ma & Tang 1992). The relatively recent extinction of this form provides an opportunity to characterize the genetic diversity and evolutionary history of spotted hyenas in East Asia.

In this study, we used ancient DNA approaches to generate mitochondrial *cytochrome b* (*cyt b*) sequences from northern Chinese Late Pleistocene *C. crocuta ultima* specimens, and radiocarbon dates from Eurasian cave hyena bones to calibrate the origin of spotted hyenas in Asia. We applied Bayesian phylogenetic analysis and temporal reconstruction using internal tip calibrations, to provide further insights into the population history of spotted hyenas in both Europe and Africa. In addition, we used Bayes factors and traditional statistical tests to compare the fit of our temporal reconstruction and previous models of hyena evolution against independent palaeontological dates, and applied Bayesian coalescent simulations to test our reconstructed model of hyena population history.

Materials and methods

Samples

We collected samples of Late Pleistocene fossil hyenas from Lingxian Cave, Qinghangdao City in Hebei Province ($n = 6$); Tonghe Bridge, Zhaodong County in Heilongjiang Province ($n = 1$); and Da'an Cave, Tonghua County in Jilin Province ($n = 3$), which are all in northern China (Fig. S1, Supporting information). Together with other faunal assemblages (see Supporting information), these records indicate that eastern Asian late Pleistocene populations of cave hyena were present across a wide variety of mammalian habitats. Samples in Lingxian Cave were estimated to be >50 kya in age through faunal comparison, via the presence of *Coelondonta* and other late Pleistocene taxa. At Tonghe Bridge, a horse bone (*Equus sp.*) found in association with the hyena specimens has been AMS-dated to 34.9 kya (Weinstock *et al.* 2005). In Da'an cave, one of

the 3 hyena teeth was dated by the Quaternary Geology & Archaeological Chronology Laboratory at Peking University at 35.52 ± 0.23 kya, while a deer bone (*Cervus sp.*) in the same layer and 15 cm from the hyena specimens was AMS-radiocarbon-dated at 34.47 ± 0.37 kya (see Supporting information). Prior to DNA analyses, the samples had been stored in closed, dry containers at room temperature for several years without any chemical treatment (Fig. S6, Supporting information).

Ancient DNA extraction and amplification

Ancient DNA extractions and PCRs were performed at the China University of Geosciences, Wuhan. Extractions and PCR setups were performed in a laboratory dedicated to ancient DNA research situated on the eastern campus. All downstream steps were performed in a molecular biology laboratory located on the western campus. Ancient DNA was extracted from 270 to 345 mg of bone/teeth powder following the methods of Rohland & Hofreiter (2007). Extract and PCR blanks were performed throughout all experiments to monitor contamination. We attempted to sequence a 713-bp-long fragment of the mitochondrial *cyt b* gene, using four overlapping primer pairs from Rohland *et al.* (2005) and five overlapping primer pairs specifically designed for this study (Table S1 & Fig. S2, Supporting information). Amplifications were performed in 20- μ L volumes using a two-step multiplex approach (Römpler *et al.* 2006). Reagent concentrations and cycling conditions were the same as described in Römpler *et al.* (2006). The nine primer pairs were separated into two nonoverlapping sets (indicated in Table S1, Supporting information) and amplified using multiplex PCR (first step), before each primer pair was used individually in singleplex PCRs with the corresponding multiplex PCR product as a template (second step). The annealing temperatures were set at 52 °C in both steps.

PCR products were purified using the QIAEX II Gel Extraction Kit (Qiagen, Germany) and cloned into the pMD18-T vector (Takara, Japan) following the supplier's instructions. The recombinant plasmids were transformed into competent *E. coli* DH5 α . White transformants obtained from LB plates containing Amp (0.1 mg/mL), X-Gal (0.04 mg/mL) and IPTG (0.024 mg/mL) were screened by PCR with the M13 primer pair. For each fragment, a minimum of eight clones, four from each of two independent primary amplifications, were sequenced at Shanghai Sangon Ltd. Company using an ABI 3700 sequencer following manufacturers' instructions. Consistent differences were found between the first and the second PCR products in 14 of the products, probably due to sequence errors resulting from template damage, so a third amplification was performed (shown

in Table S1, Supporting information) to determine which sequence was reproducible (Hofreiter *et al.* 2001).

For two of the specimens from Da'an Cave in Jilin Province (DARD-1 and DARD-3), three fragments of *cyt b* (indicated in Table S1, Supporting information 279 bp in total) were independently replicated at the Australian Centre for Ancient DNA (ACAD) (see Supporting information).

Alignment and phylogenetic analyses

Sequence alignments were carried out using the software package GENEIOUS PRO. 5.3.4 (Drummond *et al.* 2011), and the assemblies were checked manually. The three newly determined DNA sequences were deposited in GenBank (Accession #KC117379-81). A total of 40 *cyt b* sequences were retrieved from GenBank: 14 fossil spotted hyena, 19 extant spotted hyena, two striped hyena (*Hyaena hyaena*), two brown hyena (*Hyaena brunnea*) and three aardwolf (*Proteles cristatus*) (Table S2, Supporting information). Three data sets were used to initiate different analyses:

Data set 1 comprises 14 sequences: three Chinese Pleistocene cave hyenas, four extant spotted hyenas, two striped hyenas, two brown hyenas and three aardwolf for which 713 bp of *cyt b* were available. This data set was used to establish the phylogenetic position of the Chinese cave hyena in the Hyaenidae family.

Data set 2 comprises 32 sequences (366 bp) for which specific sampling locations could be traced: three Chinese Pleistocene cave hyenas, 14 fossil spotted hyenas from Western Eurasia and the Pacific coast of Russia, and 15 modern spotted hyena samples. This data set was used to investigate the relationships among haplotypes of spotted hyenas through network analyses.

Data set 3 comprises 32 sequences (366 bp) for which dates can be associated with the samples: three Chinese Pleistocene cave hyenas, 10 fossil spotted hyenas from Western Eurasia and the Pacific coast of Russia that have radiocarbon dates, and 19 modern spotted hyena samples. This data set was used for phylogenetic analyses and molecular dating between spotted hyena populations.

We first compared the three new Chinese *C. crocuta ultima* sequences (DARD-1, DARD-2 and DARD-3) to the four extant spotted hyena sequences in GenBank for the 713 bp of *cyt b* (Accessions: AY048786, AY928676, AY170114, AF511064; see Table S3, Supporting information). To establish the position of the Chinese cave hyena in the Hyaenidae family, a phylogenetic analysis of Data set 1 was performed using the program PHYL v3 (Guindon *et al.* 2010). The best of NNI and SPR moves were used for the tree topology search, and the substitution model TN+I was selected through

comparison of Bayesian Information Criterion scores in MODELGENERATOR v0.85 (Keane *et al.* 2006). To investigate the relationships among haplotypes of spotted hyenas, we conducted a median joining network analysis from Data set 2 using the program NETWORK v4.6.0.0 (Bandelt *et al.* 1999).

We then performed Bayesian analyses on Data set 3 using BEAST v1.6.1 (Drummond & Rambaut 2007) to address the phylogenetic relationships and dates between the cave hyenas from China, *C. crocuta spelaea* specimens from other locations in Eurasia, and living spotted hyenas in Africa. The substitution model HKY+G was selected through comparison of Bayesian Information Criterion scores in MODELGENERATOR v0.85 (Keane *et al.* 2006). The MCMC analyses were run for 100 000 000 iterations, with posterior samples drawn every 10 000 steps. Results were checked in Tracer v1.5 after 10% burn-in, where all parameters showed sufficient sampling, indicated by effective sample sizes above 200 (Rambaut & Drummond 2007). A strict molecular clock was used, and a constant population size was set as tree prior (see Supporting information). To deal with the issue of time dependence of molecular rates (Ho *et al.* 2008, 2011a), and the effect of deep calibrations on intraspecific dating (Ho *et al.* 2008), two sets of dates were used as calibration points to calculate the most recent common ancestor (MRCA) of fossil and extant spotted hyenas: (i) the radiocarbon dates associated with the ancient sequences ('internal calibration'); (ii) the radiocarbon dates, as per (i), plus the divergence between spotted hyenas and striped/brown hyenas (here represented by a striped hyena specimen) using a log normal distribution with a minimum bound of 9 Ma and 95% of the prior probabilities younger than 9.5 Ma ('external calibration').

To check if the signal from the radiocarbon dates associated with the ancient sequences was sufficient to calibrate the spotted hyena phylogeny, a 'date randomization test' was performed (Ho *et al.* 2011b), in addition to a replicated BEAST run with the 'prior only' option (see Supporting information).

Model comparison and hypothesis testing

A Bayes factor analysis of the two timescale models (internal and external calibrations) given additional independent fossil dates (earliest appearance of *C. crocuta* in China and the estimated time of arrival of cave hyena in western Eurasia) was calculated empirically from the BEAST estimates of the two basal nodes (see Supporting information). To statistically test the plausibility of the palaeontological fossil record against each timescale model separately, hypothesis testing was used to estimate the strength of evidence for each

model via *P*-values (see Supporting information). In each case, the null hypothesis was that the palaeontological fossil dates stem from the same population history as the posterior distribution of dates for each node (calculated in BEAST using the appropriate calibration model). The alternate hypothesis is that the palaeontological fossil dates do not stem from the same population history as the posterior distribution of dates for each node.

Serial coalescent simulations

Bayesian Serial Simcoal (BAYESSC, Anderson *et al.* 2004) was used to simulate data sets under three demographic models: a null model of panmixia, an Out-of-Africa model proposed by Rohland *et al.* (2005) using fossil calibrations and a Eurasian origins model proposed in this study using tip dated ancient DNA samples. The models differed in terms of the prior distributions on divergence order/times between clades, with the null panmictic model having no divergence events. Four different mutation rate estimates were used in the simulations: two constant mutation rates calculated from BEAST analyses (external calibrations as per Rohland *et al.* (2005), and internal calibrations from this study), and two time-dependent mutation rates (using linear and exponential decay equations; see Supporting information). The summary statistics used to compare the simulations to the observed data sets (Data set 3) was F_{ST} and private alleles between each of the 5 clades (A1, A2, B, C and D). Bayesian Serial Simcoal was used to generate 10 million simulations under each of the eight divergence models, plus 500 000 simulations under null models of panmixia for each of the four mutation rates.

Results and discussion

Sequence variation in Pleistocene fossil and extant spotted hyenas

Ancient specimens contain only trace amounts of highly fragmented DNA molecules, and it is important to demonstrate that the ancient DNA sequences have not been affected by contamination or DNA damage (Poinar 2003; Knapp *et al.* 2011). Therefore, the ten Late Pleistocene hyena specimens from northern China were analysed using appropriate ancient DNA techniques (Cooper & Poinar 2001) including independent extraction and replication, and multiple sequencing reactions (Table S1, Supporting information). Nine overlapping fragments (size range is 127–171 bp including primers) of a 713-bp-long region of the mitochondrial *cyt b* gene were amplified for the three specimens from

Da'an Cave at Tonghua County in Jilin Province using multiplexed PCR (Table S1 and Fig. S2, Supporting information). These amplified fragments were used to build the 713-bp contigs for each specimen with the sequences obtained from multiple extractions, amplifications and cloning with clean control reactions. Most importantly, identical sequences were obtained when experiments were independently replicated at the State Key Laboratory for Biogeology and Environmental Geology at China University of Geosciences (Wuhan) and the Australian Centre for Ancient DNA (ACAD) at the University of Adelaide, Australia (Table S1, Supporting information). Only one 100-bp-long fragment could be amplified for a sample collected at Tonghe Bridge in Zhaodong County, Heilongjiang Province, while no fragments could be recovered for six Lingxian Cave samples collected from Qinhuangdao City, Hebei Province, despite multiple attempts. As a result, we considered only the Da'an Cave samples for further phylogenetic analyses.

The three new Chinese *C. crocuta ultima* sequences (DARD-1, DARD-2 and DARD-3) differed from each other at 1–2 positions across the full 713-bp sequence, and from a reference modern spotted hyena sequence (GenBank #AY048786) at 36, 37 and 35 polymorphic sites (~5%), respectively. In contrast, the other three homologous sequences for living spotted hyena available from GenBank have only 18, 18 and 24 polymorphic sites (~3%) across the same fragment (Table S3, Supporting information). The Da'an Cave sequences are identical to the only Far East Asian Late Pleistocene cave hyena sequenced to date (#DQ157555) for the 366 bp where they overlap. DQ157555 is a 366-bp fragment of *cyt b* generated from a specimen from the Pacific coast of Russia in a previous study (Rohland *et al.* 2005). The short 100-bp sequence obtained from the Tonghe Bridge specimen was also identical. The lack of genetic diversity in such widely geographically distributed samples suggests a marked lack of diversity in the far eastern population of Late Pleistocene *C. crocuta*.

Phylogenetic tree and network

The phylogenetic position of the three new Chinese cave hyenas (*C. crocuta ultima*) in the Hyaenidae was inferred using Data set 1 (713 bp) in a maximum-likelihood analysis, with homologous sequences of the four extant species in Hyaenidae. The Chinese specimens form a monophyletic clade, sister to the living spotted hyenas (Fig. 1). The rest of the phylogeny is consistent with previous morphological (Kurtén 1956) and molecular studies based on nuclear genes (Koeplli *et al.* 2006).

A network analysis of the three new Chinese ancient DNA sequences with 29 published sequences (Data set 2; 366 bp) representing both extinct cave hyenas and living spotted hyenas retrieved a similar overall network profile as in Rohland *et al.* (2005), distributed into four haplogroups (Fig. 2a): an extinct western Eurasian and extant northern African lineage A; an extinct western European lineage B; an extant southern African lineage C; and an extinct Far East Asian lineage D. Lineage D includes the three new Chinese sequences from this study, plus the previously sequenced specimen from the Russian Pacific Coast.

Previous molecular studies (Rohland *et al.* 2005) have suggested that the Late Pleistocene Eurasian cave hyenas (*C. crocuta spelaea*), lineages A and B in Fig. 3, were unlikely to represent either distinct species or subspecies as these lineages are nested within the genetic variation of living spotted hyena populations. In contrast, the Far East Asian cave hyena specimens form the basal lineage (D), with a notably long branch. While such mtDNA patterns are insufficient to draw taxonomic conclusions, it is notable that the Far East Asian *C. crocuta ultima* can be distinguished from Late Pleistocene cave hyenas through a much more robust and shorter-limbed skeleton. It also differs from extant *C. crocuta* in having a hypertrophied dentition with extreme hypsodonty of the bone-cracking premolars (Kurtén 1956).

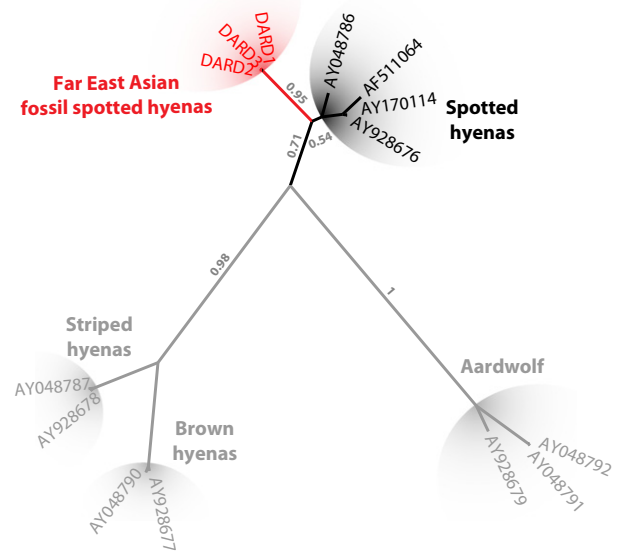

Fig. 1 Phylogenetic analysis. Maximum-likelihood tree of the Hyaenidae based on the 713-bp *cytochrome b* data set, indicating the basal position of the Chinese cave hyenas.

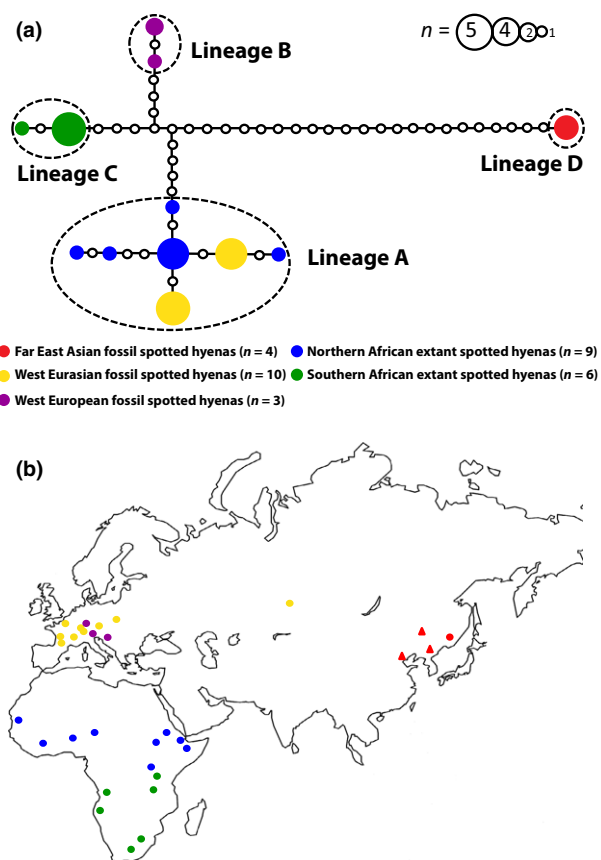

Fig. 2 Phylogeographic distribution and median joining network of late Pleistocene and living spotted hyenas analysed here. (a) Bayesian analyses based on 366-bp mitochondrial *cytochrome b* sequences of spotted hyenas, using only ancient and modern specimens with precise geographic localities (Table S1, Supporting information). (b) Geographic distribution of Pleistocene and recent Eurasian and African specimen localities. Samples in this study are indicated by red filled triangles; samples reported in Rohland *et al.* (2005) are indicated by colour-filled circles.

Estimated divergence dates and the rates curve

Bayesian analyses were used to investigate the phylogenetic relationships and divergence dates of the various cave and spotted hyena populations. The alignment was limited to the 366 bp region to facilitate comparison with previously published sequences from radiocarbon-dated ancient cave hyena bones, and aligned with modern spotted hyena sequences (Data set 3). To contrast the molecular timescales obtained from different calibration sources, two analyses were conducted: (i) using a striped hyena sequence as an outgroup and the palaeontological record to calibrate the root of the tree (external calibration), as per Rohland *et al.* (2005); and (ii) using radiocarbon dates of the ancient samples (AMS) as calibration points for the tips of the tree (internal calibration). To investigate whether the structure

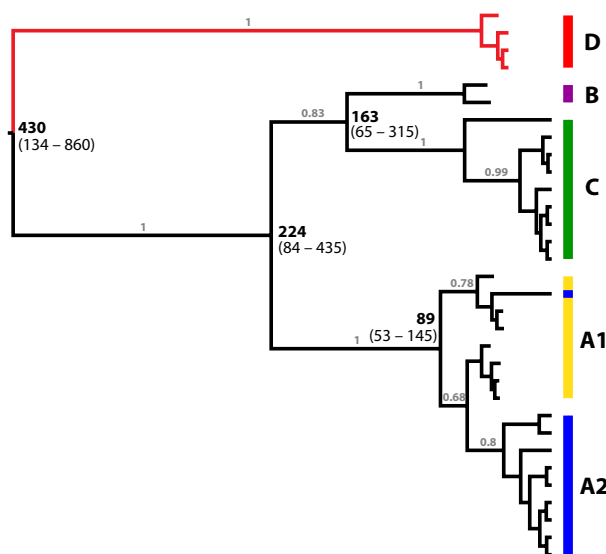

Fig. 3 Phylogenetic analysis. Maximum clade credibility tree estimated using Bayesian analysis of fossil and living spotted hyenas, based on a 366-bp data set and calibrated with the radiocarbon dates of all ancient samples as tip dates. The colours correspond to the different geographic areas shown in Fig. 1. Molecular rate calculations estimate that the Far East Asian basal branch D diverged about 430 kya, followed by the split between lineage A and the ancestor of lineages B and C around 224 kya. Lineages B and C diverged around 163 kya, while the western Eurasian lineage (A1) and the southern African lineage (A2) separated about 89 kya.

and distribution of the AMS-dated Late Pleistocene specimens contained sufficient evolutionary information to generate a meaningful internally calibrated rate estimate, the dates were randomized with respect to the sequences and re-analysed. The 95% High Posterior Density (HPD) of the rate calculated from the randomized analyses showed no overlap with the mean rate estimated without randomization, indicating that the radiocarbon dates associated with the ancient samples contain sufficient temporal information to calibrate the phylogeny (Ho *et al.* 2011b, Fig. S4a, Supporting information). Replication of the analysis with no data (prior only) also shows that the temporal inferences are not only driven by the priors, but are a result of the phylogenetic signal from the genetic data combined with the calibration dates (Fig. S4b, Supporting information). In addition, node ages and molecular rates are consistent when using either the 35.52 kya direct AMS dating of DARD-3 or the 34.47 kya (deer bone AMS dating proxy) calibration dates for the three Chinese specimens (See Fig. S5, Supporting information).

Both Bayesian analyses (using internal and external calibrations) yielded the same tree topology. Lineage D sequences from Far East Asia (China and Russia) formed a long basal branch within *C. crocuta* supported

by a bootstrap value of 100%, followed by the divergence of lineage A (Europe and northern Africa), which separated from the ancestor of lineages B and C (Figs 3 & S3, Supporting information).

When Miocene (9–9.5 Ma) fossils marking the divergence of *Crocota* and *Hyaena/Parahyaena* (Turner *et al.* 2008) were used as calibration points (external calibration), the divergence events within the spotted hyena phylogeny were estimated to be quite ancient (1.15–3.22 Ma), similar to those obtained in Rohland *et al.* (2005) which used a 10 Ma point calibration (Fig. S3, Supporting information). The Rohland *et al.* study estimated divergence dates for lineage D at 3.48 Ma (2.25–5.09 Ma), and lineages A/B/C between 1.46–1.26 Ma (0.83–2.4 Ma), and used these dates to explain the Pleistocene phylogeography of spotted hyena by suggesting that they represented three migrations out of Africa to Eurasia (see Fig. 4). However, there are several reasons to question a multiple migration scenario out of Africa. First, the estimated dates are inconsistent with the palaeontological data since *Crocota* fossils from the Late Pliocene or early Pleistocene do not appear to be *C. crocuta* (Qiu *et al.* 2004; Werdelin & Lewis 2008). For example, the 3.4-Ma-old *C. eturono* in west Turkana, 2.3-Ma-old *C. honanensis* in China and 1.6- to 1.2-Ma-old *C. ultra* in Israel and the Levant are all morphologically distinct from modern *C. crocuta* (Kurtén 1968; Werdelin & Lewis 2008; Martinez-Navarro *et al.* 2009). Instead these fossils are more likely to record the geographical appearance of the genus *Crocota* in these areas, rather than the species *C. crocuta*. Second, the phylogeographic distribution does not easily fit an Out-of-Africa dispersal model. For example, the close genetic connection between the extinct western European lineage B

and the extant southern African lineage C is difficult to explain without a contribution from the geographically intermediate northern African extant lineage A. Similarly, the absence of lineages B and D in Africa would require either *in situ* evolution of each lineage in different geographic areas, or multiple lineage extinction events to have occurred within the source population.

When the phylogenetic analyses were repeated using only the radiocarbon dates associated with the ancient sequences as tip calibration points (internal calibration), the topology remained the same, but the estimated divergence dates were almost an order of magnitude younger. Lineages D, A and B/C were estimated to diverge around 430 (134–860), 224 (84–435) and 163 (65–315) kya (Fig. 3). The difference in timescales inferred from calibrations using either Miocene fossils or AMS-radiocarbon dates has been previously observed in other groups, including carnivores (Austin *et al.* 2013). In general, radiocarbon dates at the tips of the tree will provide better calibration points (i.e. less biased and more accurate) when inferring the timescale of intra-population phylogenies, such as the spotted hyena, than fossil dates deeper in time which are considerably further away from the events of interest (Ho *et al.* 2008). Furthermore, analyses of recent events are known to be inaccurate when older fossil calibration points are used, due to the temporal dependence of molecular rates (i.e. termed the ‘rates curve’; Ho *et al.* 2005, 2011a), where evolutionary rates calculated over short timescales (e.g. at intraspecific level) appear faster than those calculated for deep periods of time (e.g. at interspecific levels).

Importantly, the younger dates obtained with internal calibrations appear to be a far better fit for the palaeontological record of *C. crocuta* in both Asia and Europe,

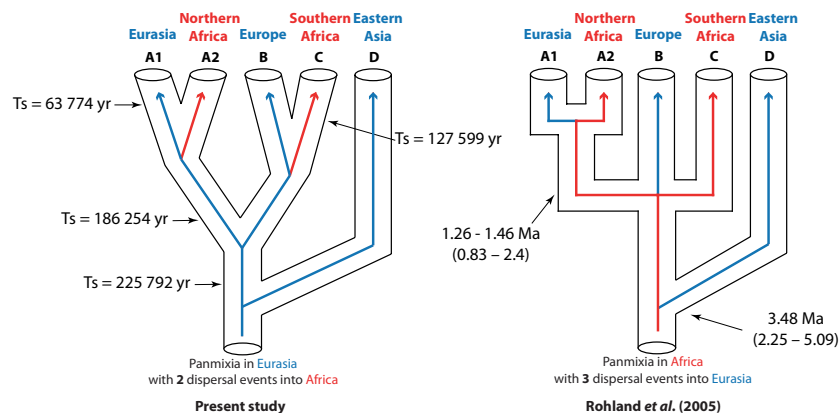

Fig. 4 Preferred BAYESSC model of spotted hyena recent evolutionary history. The large diagram represents the BayeSSC model with the lowest AIC value (dates are maximum-likelihood estimates from the BAYESSC analysis). The most parsimonious explanation of this model is that an ancestral panmictic population of spotted hyenas occupied Eurasia (blue arrows), with dispersal into Africa (red arrows), rather than an ancestral panmictic population in Africa that had three dispersal events into Eurasia, as proposed by Rohland *et al.* (2005); represented by the smaller diagram, with dates from the original publication.

with the earliest *C. crocuta ultima* in China detected around 400–230 kya (Turner 1990; Zhou *et al.* 2000; Qiu *et al.* 2004), while the cave hyena appeared in western Eurasia sometime after 300 kya (García & Arsuaga 2001; Baryshnikov & Tsoukala 2010). To examine the discrepancy between date estimates obtained using either internal (radiocarbon dates) or external (root) calibrations, the posterior distribution of estimated dates for the two basal nodes of the spotted hyena phylogeny was plotted against the first appearance dates in China and western Eurasia. As the latter two dates were not used in the phylogenetic analyses, they provide an independent validation test for the two timescales (Fig. 5). Hypothesis testing of the mismatch between the externally calibrated timescale and the palaeontological record found significant differences at the 5% level (node representing the earliest *C. crocuta ultima* in China, P -value = 0.003; node representing appearance of cave hyena in western Eurasia, P -value = 0.021). In contrast, the internally calibrated timescale was congruent with the palaeontological record (earliest *C. crocuta ultima* in China, P -value = 0.653; first appearance of cave hyena in western Eurasia, P -value = 0.337). A Bayes Factor analysis of the fit of both

timescales against the first appearance dates produced decisive support for the internally calibrated model (BF = 872, see Supporting information). We therefore suggest that a single dispersal event introducing lineages A and C into Africa from an ancestral population in Eurasia is a more parsimonious explanation of the observed phylogeographic pattern (Fig. 4).

To evaluate the support for the two evolutionary models (i.e. the externally calibrated Out-of-Africa model of Rohland *et al.* (2005), and the internally calibrated Eurasian model proposed here) given the genetic data and fossil dates available, Bayesian coalescent simulations were performed using two constant and two time-dependent molecular evolutionary rates (see Supporting information). The support for a null hypothesis of total panmixia was also evaluated. The internally calibrated model proposed here had the lowest Akaike Information Criterion value of the models considered (Model H in Fig. S7 Supporting information, with an AIC = 258.18). The preferred model proposes that clade D diverged from clades A/B/C 225 kya, which fits relatively well with the fossil record in China where the earliest *C. crocuta ultima* specimen dates to 400–230 kya (Markova *et al.* 1995; Jenks & Werdelin 1998; Werdelin

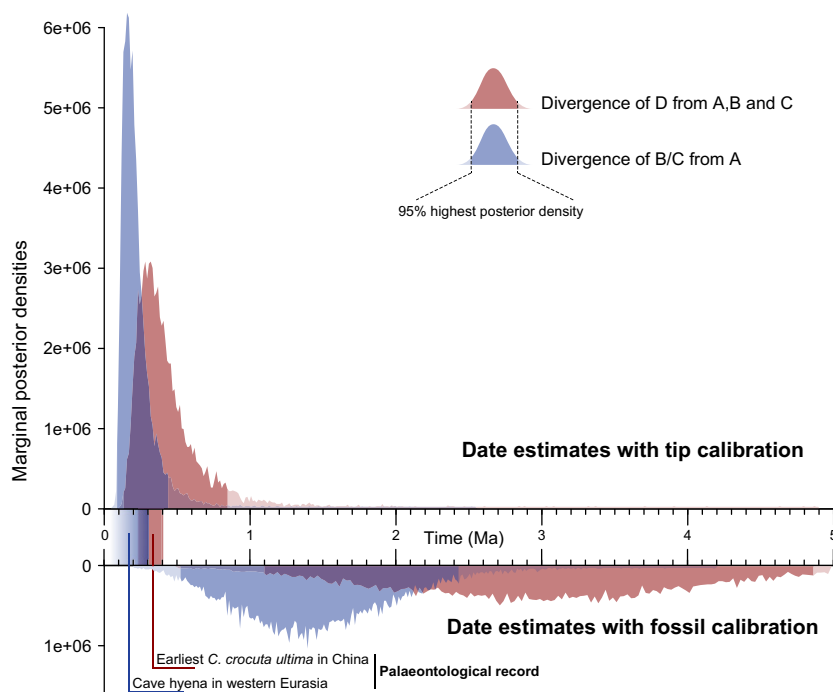

Fig. 5 Comparison of date estimates from both calibration methods against the palaeontological record. Marginal posterior densities of the two basal nodes of the spotted hyena phylogeny, reported from the BEAST analysis using radiocarbon dates (upper section of the figure) or external fossil dates (lower section) as calibrations. The earliest appearance of *C. crocuta* in China and the estimated time of arrival of cave hyena in western Eurasia from the palaeontological record are reported as red and blue bars, respectively, on the chronology (central section of the figure). There is a clear fit between the estimated dates for the two basal nodes of the spotted hyena phylogeny and the palaeontological chronology when tip calibrations are used. However in contrast, the 95% high posterior density of estimated dates for the same nodes using external fossil calibration do not overlap with the palaeontological chronology.

1999). Clades B/C diverged from clade A 186 kya, clade B diverged from clade C 128 kya and clade A1 and A2 diverged from each other only 64 kya (see Table S6, Supporting information for 95% CIs of nodes for all models). The combination of this model and the time-dependent linear decay mutation rate has a 99.93% chance of being the best model among the set of twelve candidate models considered (Table S5, Supporting information).

Recent central Eurasian evolutionary history of spotted hyenas

The combined picture from the phylogenetic trees, the fossil and molecular dates, and the coalescent simula-

tions suggest an alternative scenario for the recent evolutionary history of spotted hyena, based around the fragmentation of an ancestral population located across the large Eurasian steppe ecosystem. The steppe ecosystem stretched from central to western Eurasia in the mid-Early Pleistocene and provided a habitat for both ungulates and other carnivores, such as cave lions (Yamaguchi *et al.* 2004; Barnett *et al.* 2006, 2009). We propose that an ancestral Eurasian hyena population across this area contained ancestral *A**, *B**, *C** and *D** lineages, among others, before being fragmented by changing environmental conditions in the middle Pleistocene (Figs 4 and 6). The far eastern portion of the population is suggested to have become isolated sometime after 430 kya, separating the ancestor of lineage D.

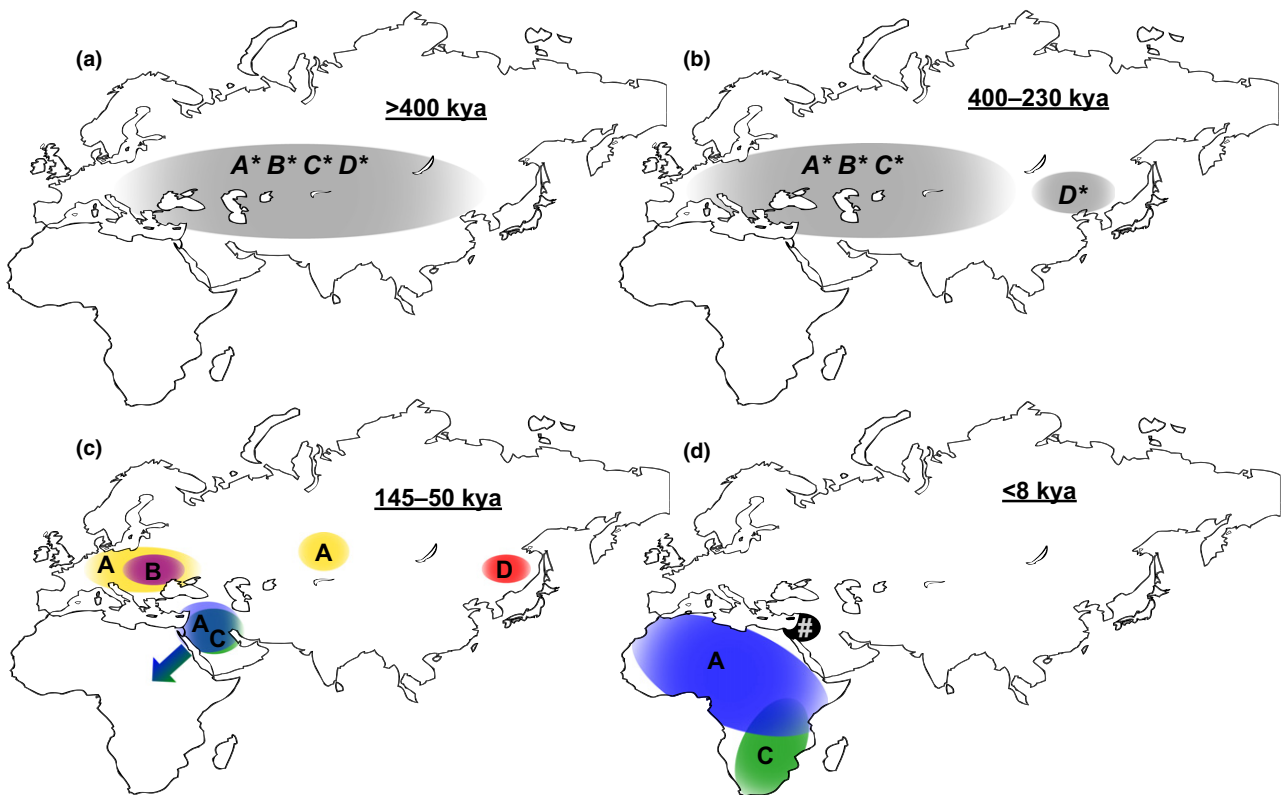

Fig. 6 Revised model of the recent evolutionary history of spotted hyenas synthesizing fossil and molecular data. (a) A large ancestral population is proposed to have existed across the steppe habitat of central Eurasia in the mid-Early Pleistocene, containing ancestral lineages of A, B, C and D (indicated with italics and asterisks); (b) The ancestral population began to fragment in the late middle Pleistocene, potentially in response to environmental changes. At some point after 430 kya, the ancestral lineage *D** was isolated in Far East Asia; (c) the A1 (Eurasian) and A2 (northern African) lineages are estimated to have separated around 90 kya (95% CI 145–53 kya), implying Lineages A1 and B were isolated in western Eurasia at some point after this, as the remnant Eurasian population re-treated into the middle East/Africa; (d) The African population was subsequently sorted into northern (A2) and southern (C) lineages while lineages A, B and D became extinct in Eurasia during the Late Pleistocene. Grey areas in (a) and (b) show the inferred distribution of the ancestral populations for different lineages. Coloured areas in (c) and (d) show the known distribution of spotted hyenas, identified by either fossil records or extant populations. The time frame in (b) and (d) is based on the *C. crocuta ultima* fossil record and in (c) on molecular dating (the estimated 145–53 kya separation of A1 and A2), constrained by the 50 kya radiocarbon date of the oldest ancient sample. The # sign represents the geographical location of the oldest *C. crocuta* remains with modern morphology (Martinez-Navarro *et al.* 2009).

The western Eurasian population (containing lineages A1 and B) must have become isolated after lineages A1 and A2 are estimated to have diverged, around 90 kya. The remnant ancestral Eurasian population subsequently re-treated into Africa where lineage A2 and C eventually became sorted into northern and southern populations (Fig. 6). The low diversity within each haplogroup in *C. crocuta* indicates that the spotted hyena populations have been subjected to population bottlenecks in the past, which is compatible with the loss of lineages from different areas. This could explain the phylogeographic structure, such as the fixation of lineage D in far eastern populations and its absence elsewhere, or the lack of lineage C in Europe.

Furthermore, modern African hyena populations (both lineages A2 and C) are morphologically distinct from fossil populations (Kurtén 1956). This distinctiveness appears very late in the fossil record and is observed first in the Middle East in Israel (Martinez-Navarro *et al.* 2009; marked with # on Fig. 6d). The exact timing of the appearance of the modern morphology is, however, unclear, because the record of Late Pleistocene *Croculta* is poor outside Europe and China, but must have occurred after 1 Ma, when an archaic morph of *Croculta* is present at Ologesailie, Kenya, in sediments dated 0.99 Ma (Werdelin & Lewis 2005). Such a late morphological shift would be compatible with the remnant Eurasian population entering, or being confined to, Africa as described in the Eurasian origins model. As a consequence, this model provides a good fit for both the timing and morphological shifts observed within the palaeontological record, and complements the initial view of *C. crocuta* evolution proposed by Kurtén (1956).

This work establishes the importance of the Chinese Pleistocene fossil record as a valuable source of DNA for the analysis of mammalian evolution across Eurasia, and the former distribution of species across the Old World. As such it complements previous studies, which have been mostly restricted to either caves in Europe or the permafrost areas of northern Siberia. The use of direct tip calibrations provides a powerful means to estimate timescales of evolution that are not dependent on deeper palaeontological records, which are necessarily less complete and accurate, and more subject to biases. Together with the statistical testing and coalescent simulations of contrasting models of population history using first appearance data and other independent palaeontological dates, this provides a new approach to the study of other Late Pleistocene mammal populations. In the case of the *Croculta*, it challenges the interpretation of divergent mtDNA lineages as representing population dispersal events rather than signatures of long-term population processes, including the random

loss of lineages through genetic drift and population bottlenecks.

Importantly, the new Eurasian origins model for *Croculta* repositions Africa as a potential refugium for species from the steppe grasslands of Eurasia as this habitat re-treated in the Pleistocene. Further investigation will be required to obtain a definitive timescale and phylogeographic description of the evolution of spotted hyenas (e.g. additional nuclear loci, samples and dates), but the approach here (direct tip calibrations and validation against the palaeontological record) provides an important new model that will be applicable to a number of other Late Pleistocene Eurasian and African mammal populations. It appears possible that other steppe grassland adapted species that are currently restricted to Africa may also have Eurasian origins and that the role of central Eurasia in recent mammal evolution needs re-evaluation.

Financial disclosure

This research was supported by 973 Program (No. 2011CB808800), the Natural Science Foundation of China (Nos. 40902008, 40972013) and the Australian Research Council. The funders had no role in study design, data collection and analysis, decision to publish or preparation of the manuscript.

Acknowledgements

We are grateful to Jian Yi, Jun-Xia Yuan in BGEG for their technical support. We thank Dr. Jeremy Austin, Dr. Wolfgang Haak and members at ACAD for their helpful comments on the manuscript. We thank Prof. Michael Hofreiter at York University for discussion on *Croculta* evolutionary models.

References

- Anderson CNK, Ramakrishnan U, Chan YL, Hadly EA (2004) Serial SimCoal: a population genetics model for data from multiple populations and points in time. *Bioinformatics*, **21**, 1733–1734.
- Austin JJ, Soubrier J, Prevosti FJ *et al.* (2013) The origins of the enigmatic Falkland Islands wolf. *Nature Communications*, **4**, 1552.
- Bandelt HJ, Forster P, Rohl A (1999) Median joining networks for inferring intraspecific phylogenies. *Molecular Biology and Evolution*, **16**, 37–48.
- Barnett R, Yamaguchi N, Barnes I, Cooper A (2006) The origin, current diversity and future conservation of the modern lion (*Panthera leo*). *Proceedings of the Royal Society B*, **273**, 2119–2125.
- Barnett R, Shapiro B, Barnes I *et al.* (2009) Phylogeography of lions (*Panthera leo* ssp.) reveals three distinct taxa and a late Pleistocene reduction in genetic diversity. *Molecular Ecology*, **18**, 1668–1677.

- Baryshnikov GF, Tsoukala E (2010) New analysis of the Pleistocene carnivores from Petralona cave (Macedonia, Greece) based on the collection of the Thessaloniki Aristotle university. *Geobios*, **43**, 389–402.
- de Bonis L (1973) *Contribution à l'étude des mammifères de l'Aquitainien de l'Agenais: rongeurs, carnivores, périssodactyles*. In: *Mémoires du Muséum national d'Histoire naturelle, Nouvelle Série (C)* **28**, pp 1–192, Paris (in French).
- Cooper A, Poinar HN (2001) Ancient DNA: do it right or not at all. *Science*, **289**, 1139.
- Diedrich C (2008) The holotypes of the upper Pleistocene *Crocota crocuta spelaea* and *Panthera leo spelaea* of the zoolithen cave hyena den and their palaeo-ecological interpretation. *Zoological Journal of the Linnean Society*, **154**, 822–831.
- Drummond AJ, Rambaut A (2007) BEAST: Bayesian evolutionary analysis by sampling trees. *BMC Evolutionary Biology*, **7**, 214.
- Drummond AJ, Ashton B, Buxton S *et al.* (2011) Geneious v5.4. Available from <http://www.geneious.com>.
- García N, Arsuaga JL (2001) Les carnivores (Mammalia) des sites du Pléistocène ancien et moyen d'Atapuerca (Espagne). *L'anthropologie*, **105**, 83–93. (in French with English abstract).
- Guindon S, Dufayard J-F, Lefort V *et al.* (2010) New algorithms and methods to estimate maximum-likelihood phylogenies: assessing the performance of PhyML 3.0. *Systematic Biology*, **59**, 307–321.
- Ho SYW, Phillips MJ, Cooper A, Drummond AJ (2005) Time dependency of molecular rate estimates and systematic over-estimation of recent divergence times. *Molecular Biology and Evolution*, **22**, 1561–1568.
- Ho SYW, Saarma U, Barnett R, Haile J, Shapiro B (2008) The effect of inappropriate calibration: three case studies in molecular ecology. *PLoS ONE*, **3**, 1615.
- Ho SYW, Lanfear R, Bromham L *et al.* (2011a) Time-dependent rates of molecular evolution. *Molecular Ecology*, **20**, 3087–3101.
- Ho SYW, Lanfear R, Phillips MJ *et al.* (2011b) Bayesian estimation of substitution rates from ancient DNA sequences with low information content. *Systematic biology*, **60**, 366–375.
- Hofreiter M, Jannicke V, Serre D, Haeseler A, Paabo S (2001) DNA sequences from multiple amplifications reveal artifacts induced by cytosine deamination in ancient DNA. *Nucleic Acids Research*, **29**, 4793–4799.
- Hu CK (1985) The history of Mammalian Fauna of Locality 1 of Zhoukoudian and its recent advances. In: *Multi-disciplinary Study of the Peking Man Site at Zhoukoudian* (eds Wu RK, Ren M, Zhu X), pp. 107–113. Science Press, Beijing. (In Chinese)
- Huang WP (1989) Taxonomy of the hyaenidae (*hyaena* and *crocota*) of the pleistocene in China. *Vertebrata Palasiatica*, **27**, 197–204. (in Chinese with English abstract).
- Jenks SM, Werdelin L (1998) *Taxonomy and systematics of living hyaenas (Family Hyaenidae)*. In: *Hyaenas: Status Survey and Conservation Action Plan* (eds Mills MGL, Hofer H), pp. 8–17. IUCN, Gland, Switzerland.
- Keane TM, Creevey CJ, Pentony MM, Naughton TJ, McInerney JO (2006) Assessment of methods for amino acid matrix selection and their use on empirical data shows that ad hoc assumptions for choice of matrix are not justified. *BMC Evolutionary Biology*, **6**, 29.
- Knapp M, Clarke AC, Horsburgh KA, Matisoo-Smith EA (2011) Setting the stage - building and working in an ancient DNA laboratory. *Annals of Anatomy*, **194**, 3–6.
- Koepfli KP, Jenks SM, Eizirik E *et al.* (2006) Molecular systematics of the hyaenidae: relationships of a relictual lineage resolved by a molecular supermatrix. *Molecular Phylogenetics and Evolution*, **38**, 603–620.
- Kurtén B (1956) The status and affinities of *Hyaena sinensis* Owen and *Hyaena ultima* Matsumoto. *American Museum Novitates*, **1764**, 1–48.
- Kurtén B (1968) *Pleistocene Mammals of Europe*. Weidenfeld and Nicholson, London.
- Liu JY (1999) Study of the Late Pleistocene mammalian remains from Miaofengshan, Beijing with discussion of the migration and extinction of *Crocota crocuta ultima*. *Longgupo Prehistoric Culture*, **1**, 128–139. (In Chinese).
- Ma AC, Tang HL (1992) On discovery and significance of a Holocene Ailuropoda-Stegodon Fauna from Jinhua, Zhejiang. *Vertebrata Palasiatica*, **30**, 295–312. (in Chinese with English summary).
- Markova AK, Smirnov NG, Kozharinov AV *et al.* (1995) Late Pleistocene distribution and diversity of mammals in northern Eurasia (PALEOFAUNA Database). *Paleontologia i Evolucio*, **28**, 5–134.
- Martinez-Navarro B, Belmaker M, Bar-Yosef O (2009) The large carnivores from 'Ubeidiya (early Pleistocene, Israel): biochronological and biogeographical implications. *Journal of Human Evolution*, **56**, 514–524.
- Poinar HN (2003) The top 10 list: criteria of authenticity for DNA from ancient and forensic samples. *International Congress Series*, **1239**, 575–579.
- Qiu ZX (1987) Die Hyaeniden aus dem Ruscium und Villafanchium Chinas. *Munchner Geowissenschaftliche Abhandlungen Reihe A*, **9**, 1–108. (in German).
- Qiu ZX, Deng T, Wang BY (2004) Early Pleistocene mammalian fauna from Longdan, Dongxiang, Gansu, China. *Palaeontologia Sinica (series C)*, **27**, 1–198.
- Rambaut A, Drummond AJ (2007) Tracer v 1.4. Available from: <http://beast.bio.ed.ac.uk/Tracer>.
- Rohland N, Hofreiter M (2007) Ancient DNA extraction from bones and teeth. *Nature Protocols*, **2**, 1756–1762.
- Rohland N, Pollack JL, Nagel D *et al.* (2005) The population history of extant and extinct hyenas. *Molecular Biology and Evolution*, **22**, 2435–2443.
- Römpler H, Dear PH, Krause J *et al.* (2006) Multiplex amplification of ancient DNA. *Nature*, **1**, 720–728.
- Shen GJ, Ku TL, Cheng H *et al.* (2001) High-precision U-series dating of locality 1 at Zhoukoudian, China. *Journal of Human Evolution*, **41**, 679–688.
- Tong HW (2007) Occurrences of warm-adapted mammals in north China over the quaternary period and their paleoenvironmental significance. *Science in China (series D)*, **50**, 1327–1340.
- Tseng ZJ, Chang CH (2007) A study of new material of *Crocota crocuta ultima* (Carnivora: Hyaenidae) from the quaternary of Taiwan. *Collection and Research*, **20**, 9–19.
- Turner A (1984) The interpretation of variation in fossil specimens of spotted hyena (*Crocota crocuta* Erxleben, 1777) from Sterkfontein valley sites (mammalian: Carnivora). *Annals of the Transvaal Museum*, **33**, 399–418.

- Turner A (1990) The evolution of the guild of larger terrestrial carnivores during the Plio-Pleistocene in Africa. *Geobios*, **23**, 349–368.
- Turner A, Antón M, Werdelin L (2008) Taxonomy and evolutionary patterns in the fossil Hyaenidae of Europe. *Geobiology*, **41**, 677–687.
- Watts HE, Holekamp KE (2007) Hyena societies. *Current Biology*, **17**, 657–660.
- Weinstock J, Willerslev E, Sher A *et al.* (2005) Evolution, systematics, and phylogeography of Pleistocene horses in the new world: a molecular perspective. *PLoS Biology*, **3**, 1373–1379.
- Werdelin L (1999) Studies of fossil hyaenas: affinities of *Lycyaenops rhomboideae* Kretzoi from Pextlörinc, Hungary. *Zoological Journal of the Linnean Society*, **126**, 307–317.
- Werdelin L, Lewis ME (2005) Plio-Pleistocene Carnivora of eastern Africa: species richness and turnover patterns. *Zoological Journal of the Linnean Society*, **144**, 121–144.
- Werdelin L, Lewis ME (2008) New species of *Crocota* from the early Pliocene of Kenya, with an overview of early Pliocene hyenas of eastern Africa. *Journal of Vertebrate Paleontology*, **28**, 1162–1170.
- Werdelin L, Solounias N (1991) The hyaenidae: taxonomy, systematics and evolution. *Fossils and Strata*, **30**, 1–104.
- Werdelin L, Yamaguchi N, Johnson WE, O'Brien SJ (2010) Felid phylogeny and evolution. In: *The Biology and Conservation of Wild Felids* (eds Macdonald DM, Loveridge A), pp. 59–82. Oxford University Press, Oxford.
- Yamaguchi N, Cooper A, Werdelin L, Macdonald DW (2004) Evolution of the mane and group-living in the lion (*Panthera leo*): a review. *Journal of Zoology*, **263**, 329–342.
- Zdansky O (1924) Jungtertiäre carnivoren chinas. *Palaeontologia Sinica (series C)*, **2**, 1–149. (in German).
- Zhou C, Lui Z, Wang Y (2000) Climatic cycles investigated by sediment analysis in Peking Man's Cave, Zhoukoudian, China. *Journal of Archaeological Science*, **27**, 101–109.

X-L.L. and A.C. designed research, G-L.S., B.L., L.J.W., X-D.H. and Q-J.C. performed research, G-L. S., J.S., V.T. and J.T. analysed data, J-Y. L., L.W. helped interpreting results, G-L. S., J.S., L.W., B.L., V.T., X-L.L. and A.C. contributed to writing the study.

Data accessibility

DNA sequences: GenBank Accessions #KC117379–81.

BEAST and BAYESSC input files are available as supplementary material.

Supporting information

Additional supporting information may be found in the online version of this article.

Fig. S1. Geographic distribution of fossil spotted hyenas in Far East Asia, showing Pleistocene hyena fossil sites in China.

Fig. S2. Schematic view of the 713 bp configs of the cyt b gene for the Pleistocene samples using nine overlapping PCR fragments.

Fig. S3. Phylogenetic tree for fossil and extant spotted hyenas.

Fig. S4. Different tests showing temporal signal in the datasets.

Fig. S5. Comparison of rates (a) and dates (b) estimates with 2 calibration dates for the Chinese samples.

Fig. S6. Photos of three Da'an Cave specimens.

Fig. S7. Posterior maximum likelihood estimators output from BAYESSC.

Fig. S8. Graph of time dependent mutation rate, showing (a) linear and (b) exponential decay relationships between the two calibration points.

Table S1. PCR primers for *Crocota crocuta ultima* mitochondrial cytochrome b gene.

Table S2. Details on sequences used in this study.

Table S3. Variations in the newly obtained ancient sequences compared to living spotted hyenas.

Table S4. Probability of observing the paleontological fossil dates under the null hypothesis that the posterior distribution of the basal nodes are either, the externally (Miocene fossil dated) calibration model or the internally (AMS radiocarbon tip dated) calibration model.

Table S5. Akaike Information Criterion (AIC) values for the twelve different model/mutation rate combinations.

Table S6. Maximum Likelihood Estimators (MLE) with lower (2.5%) and upper (97.5%) confidence bounds for divergence times from the Bayesian Serial Simcoal (BAYESSC) analysis (for divergence models only – H1 and H2).

Table S7. Mutation rates used in the BAYESSC analysis, and the method used to calculate the time dependent mutation rates. Additional references